



Memorandum

To: Bassett Creek Watershed Management Commission
From: Barr Engineering Co.
Subject: Item 4F – Golden Villas Apartments Project – Golden Valley
BCWMC August 20, 2015 Meeting Agenda
Date: August 12, 2015
Project: 23270051 2015 2050

4F Golden Villas Apartments Project – Golden Valley

Summary:

Proposed Work: Building and parking lot demolition and apartment building construction

Basis for Commission Review: Use of underground storage for stormwater treatment

Impervious Surface Area: Increase 0.13 acres

Recommendation: Conditional approval

General Background & Comments

The proposed project includes removal of two commercial buildings and parking lots; construction of a new apartment building, parking lot, driveways, and sidewalks; and installation of an underground stormwater treatment system. The project is in the Bassett Creek Main Stem subwatershed at 9130 and 9220 State Highway 55 (near the intersection of State Highway 55 and Interstate 169). The project site is 2.6 acres. The proposed project results in an increase of 0.13 acres of impervious surface and a total proposed impervious area of 2.15 acres. The applicant has submitted a separate application for demolition activities on the site that was reviewed administratively by BCWMC staff.

Floodplain

The project does not involve work in the Bassett Creek floodplain.

Wetlands

The project does not involve work in wetlands. The City of Golden Valley is the LGU for administering the Minnesota Wetland Conservation Act of 1991.

Stormwater Management

Under existing conditions runoff from the site is routed to the north ditch of State Highway 55. Under proposed conditions the majority of the site will be routed to an underground stormwater management system in the southwest corner of the site which will discharge to the north ditch of State Highway 55. Small pervious areas around the perimeter of the site will follow existing drainage patterns with the untreated runoff routed to the north ditch of State Highway 55.

To: Bassett Creek Watershed Management Commission
From: Barr Engineering Co.
Subject: Item 4F – Golden Villas Apartments Project – Golden Valley
Date: August 12, 2015
Page: 2
Project: 23270051 2015 2050

Water Quality Management

There is currently no water quality treatment provided on the site. Because the project is a redevelopment, the parcel size is less than five acres, and the added impervious surface is greater than 2,000 square feet, the project must meet the BCWMC's nondegradation water quality treatment requirements. An underground StormTech chamber system with infiltration into the underlying sandy soils is proposed to provide water quality treatment on site for the redevelopment. A StormTech isolator row will be used to provide pretreatment and access for inspection and maintenance.

Erosion and Sediment Control

Since the area to be graded is greater than 10,000 square feet, the proposed project must meet the BCWMC erosion control requirements. Proposed temporary erosion control features include silt fence and two rock construction entrances.

Recommendation

Conditional approval based on the following comments:

1. Details for the erosion control devices (silt fence, construction entrance, and inlet protection) must be shown on the plans.
2. Inlet protection must be shown on the proposed catch basins and any downgradient catch basins on Golden Valley Road.
3. Silt fence must be installed along the northern portion of the site between the entrance driveways.
4. The following erosion control notes should be added to the plans:
 - Vehicle tracking of sediment from the construction site (or onto streets within the site) must be minimized by installing rock construction entrances (with a berm with a minimum height of 2 feet above the adjacent roadway and with maximum side slopes of 4:1), rumble strips (mud mats), wood chips, wash racks, or equivalent systems at each site access.
 - Soils tracked from the site by motor vehicles must be cleaned daily (or more frequently, as necessary) from paved roadway surfaces throughout the duration of construction.
 - Erosion control devices must be deployed and maintained for the duration of site construction.
 - All exposed soil areas must be stabilized as soon as possible, but in no case later than 14 days after the construction activity has temporarily or permanently ceased.
 - Temporary or permanent mulch must be uniformly applied by mechanical or hydraulic means and stabilized by disc-anchoring or use of hydraulic soil stabilizers.





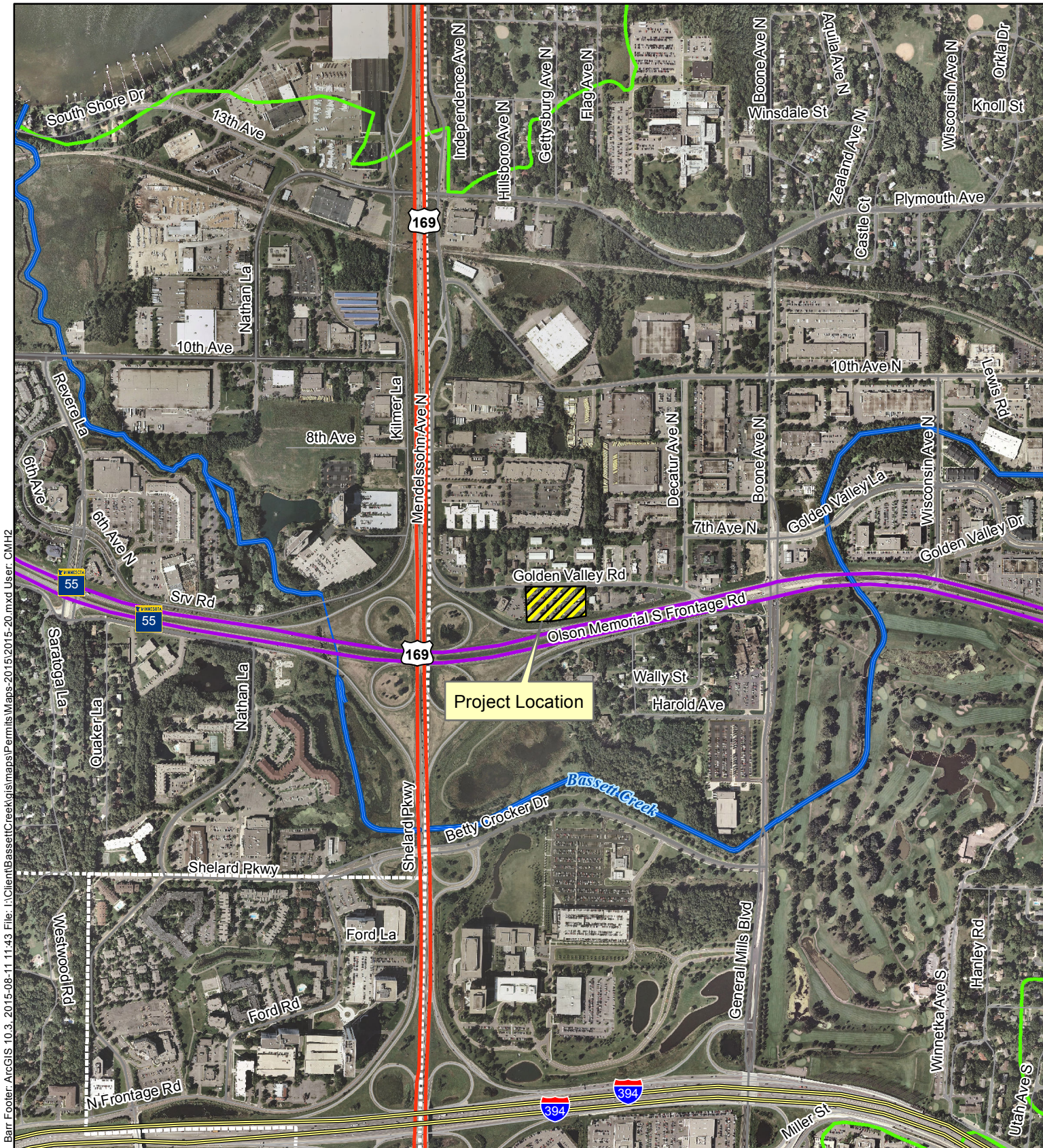

To: Bassett Creek Watershed Management Commission
From: Barr Engineering Co.
Subject: Item 4F – Golden Villas Apartments Project – Golden Valley
Date: August 12, 2015
Page: 3
Project: 23270051 2015 2050

- A temporary vegetative cover consisting of a suitable, fast-growing, dense grass-seed mix spread at 1.5 times the usual rate per acre must be specified. If temporary cover is to remain in place beyond the present growing season, two-thirds of the seed mix shall be composed of perennial grasses.
 - A permanent vegetation cover consisting of sod, a suitable grass-seed mixture, or a combination thereof must be specified. Seeded areas shall be either mulched or covered by fibrous blankets to protect seeds and limit erosion.
5. Conflicting information about the underground treatment system has been provided. The runoff storage computations and HydroCAD model indicate that a 4-foot diameter pipe will be embedded in a rock trench with 3 feet of rock below the outlet. However, a design for a StormTech system by ADS was also provided. Applicant must clarify which system is to be installed and provide appropriate runoff volume computations.
 6. The underground infiltration system must be designed to have a drawdown time of 48 hours or less. Based on the Minnesota Stormwater Manual, the design infiltration rate for SP soils should be 0.8 inches per hour. This would result in a maximum ponding depth of 38.4 inches. Applicant must provide drawdown computations for the system and adjust the design as necessary.
 7. Review of soil boring logs indicates trace fragments of bituminous pavement in the fill soils. Applicant should clarify if the fill soils will be removed at the location of the StormTech system and confirm the soils are suitable for infiltration.
 8. Details for the inlet and outlet structures to the StormTech system must be shown on the plans.
 9. The invert elevation of the outlet into the north State Highway 55 ditch appears to be approximately 0.8 feet above the invert of nearby inlets. Applicant should adjust the outlet elevation to match existing grade to minimize erosion potential.
 10. The velocity at the outlet from the StormTech system to the north State Highway 55 ditch exceeds 21 feet per second when the pipe is flowing full. A drop structure should be added or other appropriate energy dissipation provided to reduce the outlet velocity in accordance with the BCWMC requirements.
 11. A maintenance agreement for the StormTech system must be developed between the owner and the City of Golden Valley.
 12. Revised drawings must be provided to the BCWMC Engineer for final review and approval.



Barr Footer: ArcGIS 10.3. 2015-08-11 11:43 File: I:\Client\BassettCreek\GIS\maps\Permits\Maps 2015\2015-20.mxd User: CMH2

Imagery Source: Aerial Express (2009)

-  Project Location
-  Bassett Creek
-  WMC Boundary
-  Major Subwatershed
-  Municipality
-  Stream



Feet

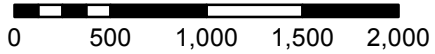

**LOCATION MAP
APPLICATION 2015-20B
Golden Villas Apartments Project
Golden Valley, MN**

StormTech MC-3500 Chamber

Designed to meet the most stringent industry performance standards for superior structural integrity while providing designers with a cost-effective method to save valuable land and protect water resources. The StormTech system is designed primarily to be used under parking lots thus maximizing land usage for commercial and municipal applications.



StormTech MC-3500 Chamber (not to scale)

Nominal Chamber Specifications

Size (L x W x H)	90" (2286 mm) x 77" (1956 mm) x 45" (1143 mm)
Chamber Storage	109.9 ft ³ (3.11 m ³)
Min. Installed Storage*	178.9 ft ³ (5.06 m ³)
Weight	134 lbs (60.8 kg)

* This assumes a minimum of 12" (305 mm) of stone above, 9" (229 mm) of stone below chambers, 9" (229 mm) of row spacing, and 40% stone porosity.

StormTech MC-3500 End Cap (not to scale)

Nominal End Cap Specifications

Size (L x W x H)	25.7" (653 mm) x 75" (1905 mm) x 45" (1143 mm)
End Cap Storage	14.9 ft ³ (0.42 m ³)
Min. Installed Storage*	46.0 ft ³ (1.30 m ³)
Weight	49 lbs (22.2 kg)

* This assumes a minimum of 12" (305mm) of stone above, 9" (229 mm) of stone below, 9" (229 mm) row spacing, 6" (152 mm) of stone perimeter, and 40% stone porosity.

Shipping

15 chambers/pallet

7 end caps/pallet

7 pallets/truck

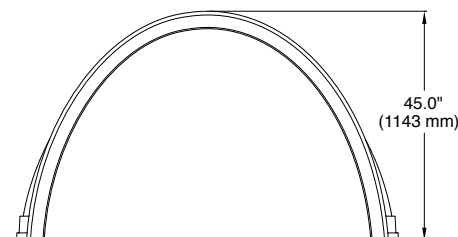
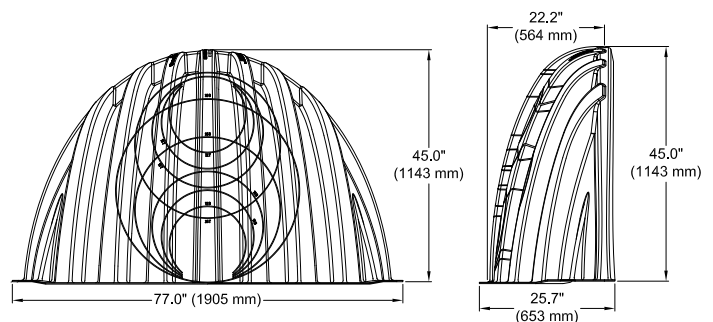
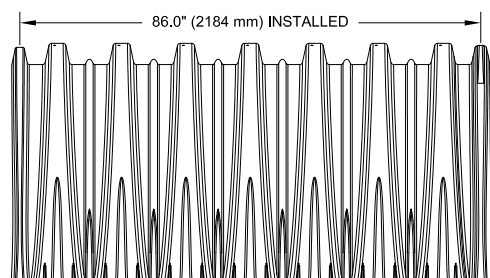
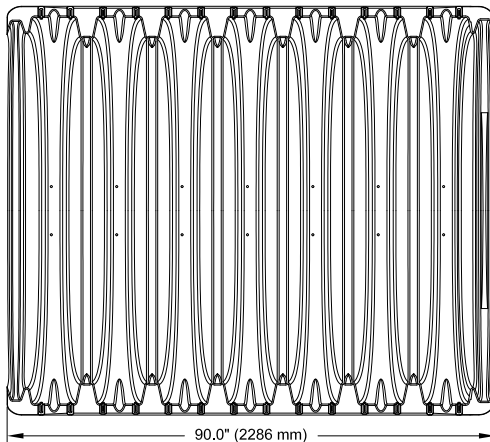

Storage Volume Per Chamber/End Cap ft³ (m³)

	Bare Unit Storage ft ³ (m ³)	Chamber/End Cap and Stone Volume — Stone Foundation Depth in. (mm)			
		9 (229)	12 (305)	15 (381)	18 (457)
MC-3500 Chamber	109.9 (3.11)	178.9 (5.06)	184.0 (5.21)	189.2 (5.36)	194.3 (5.5)
MC-3500 End Cap	14.9 (0.42)	46.0 (1.33)	47.7 (1.35)	49.4 (1.40)	51.1 (1.45)

NOTE: Assumes 40% porosity for the stone plus the chamber/end cap volume. End Cap volume assumes 6" (152mm) stone perimeter.

Volume of Excavation Per Chamber/End Cap in yd³ (m³)

	Stone Foundation Depth in. (mm)			
	9 (229)	12 (305)	15 (381)	18 (457)
MC-3500	12.4 (9.5)	12.8 (9.8)	13.3 (10.2)	13.8 (10.5)
End Cap	4.1 (3.1)	4.2 (3.2)	4.4 (3.3)	4.5 (3.5)

NOTE: Assumes 9" (229 mm) of separation between chamber rows, 6" (152 mm) of perimeter in front of end caps, and 24" (610 mm) of cover. The volume of excavation will vary as depth of cover increases.

General Cross Section

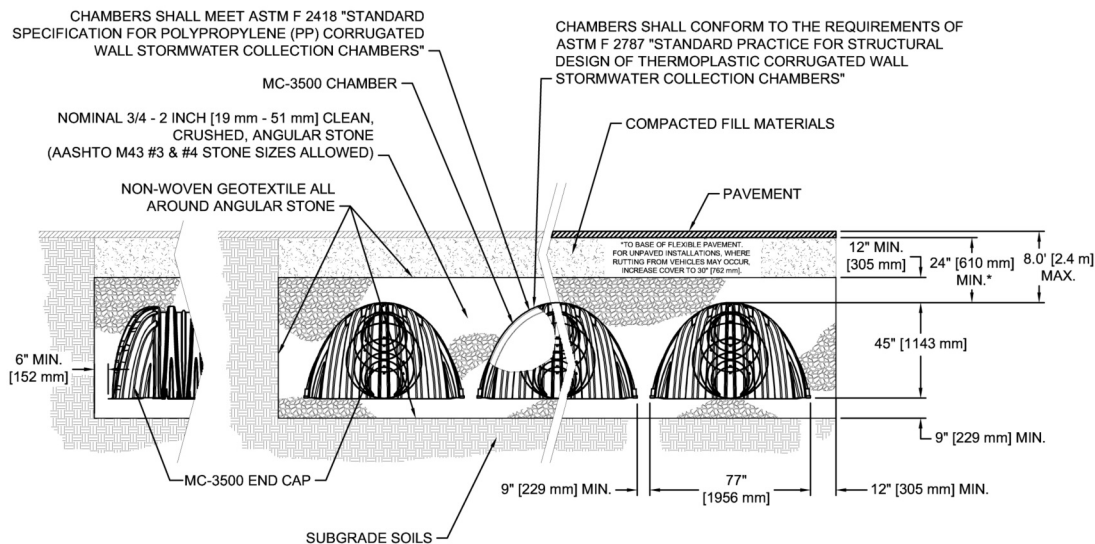

NOTES:

1. THIS CROSS SECTION PROVIDES GENERAL INFORMATION FOR THE MC-3500 CHAMBER. STORMTECH MC-3500 CHAMBERS MUST BE DESIGNED AND INSTALLED IN ACCORDANCE WITH THE MC-3500 DESIGN MANUAL AND MC-3500 CONSTRUCTION GUIDE.
2. PROPERLY INSTALLED MC-3500 CHAMBERS PROVIDE THE LOAD FACTORS SPECIFIED IN THE AASHTO LRFD BRIDGE DESIGN SPECIFICATIONS FOR EARTH AND LIVE LOADS WITH CONSIDERATION FOR IMPACT AND MULTIPLE PRESENCES.
3. PERIMETER STONE MUST ALWAYS BE BROUGHT UP EVENLY WITH BACKFILL OF BED. PERIMETER STONE MUST EXTEND HORIZONTALLY TO THE EXCAVATION WALL FOR BOTH STRAIGHT OR SLOPED SIDEWALLS.

Amount of Stone Per Chamber

ENGLISH tons (yd ³)	Stone Foundation Depth			
	9 in.	12 in.	15 in.	18 in.
MC-3500	9.1 (6.4)	9.7 (6.9)	10.4 (7.3)	11.1 (7.8)
End Cap	4.1 (2.9)	4.3 (3.0)	4.5 (3.2)	4.7 (3.3)
METRIC kg (m ³)	229 mm	305 mm	381 mm	457 mm
MC-3500	8220 (4.9)	8831 (5.3)	9443 (5.6)	10054 (6.0)
End Cap	3699 (2.2)	3900 (2.3)	4100 (2.4)	4301 (2.6)

NOTE: Assumes 12" (305 mm) of stone above, and 9" (229 mm) row spacing, and 6" (152mm) of perimeter stone in front of end caps.



A division of **ADS**

70 Inwood Road, Suite 3 | Rocky Hill | Connecticut | 06067

860.529.8188 | 888.892.2694 | fax 866.328.8401 | fax 860-529-8040 | www.stormtech.com



ADS "Terms and Conditions of Sale" are available on the ADS website, www.ads-pipe.com.

Advanced Drainage Systems, the ADS logo, and the green stripe are registered trademarks of Advanced Drainage Systems.

StormTech® is a registered trademark of StormTech, Inc

The Green Building Council Member logo is a registered trademark of the U.S. Green Building Council.

S150909 03/2014