

Bassett Creek 3rd Avenue and 2nd Street Tunnel Inspection Report



Prepared for
Bassett Creek Watershed Management Commission

Inspection Date: October 2020

3rd Avenue and 2nd Street Tunnel Inspection Report

Inspection Date: October 2020

Contents

1	Executive Summary	1
1.1	Recommendations	2
1.2	Inspection	2
1.2.1	3 rd Avenue Tunnel.....	2
1.3	Repairs, Maintenance.....	2
1.3.1	3 rd Avenue Tunnel	2
1.3.2	I-94/2 nd Street Tunnel.....	3
2	Background.....	4
2.1	Tunnel System Construction Phases.....	4
2.1.1	Phase 1: I-94/2 nd Street Tunnel.....	4
2.1.2	Phase 2: 3 rd Avenue Tunnel	5
2.1.3	Phase 3: Double Box Culvert.....	5
2.2	Inspection History.....	6
3	2019 Inspection Summary.....	8
3.1	Access Considerations	8
3.1.1	USACE Coordination	8
3.1.2	Tunnel Outlet	9
3.1.3	Washington Avenue Shaft	10
4	NASSCO Rating System Definitions	11
4.1	PACP Categories	11
4.1.1	Structural Defects.....	11
4.1.2	Operations and Maintenance Defects	11
4.1.3	Construction Features.....	11
4.1.4	Miscellaneous Features.....	11
4.2	PACP Condition Grades.....	11
4.2.1	Grading of Continuous Defects	12
5	Inspection Findings.....	13
5.1	I-94/2 nd Street Tunnel	13
5.1.1	Outlet Structure.....	13

5.1.2	12' Diameter Circular	14
5.1.3	15'-6" Tall x 10'-0" Wide Cathedral Arch.....	14
5.2	3 rd Avenue Tunnel.....	15
5.2.1	15'-6" Tall x 8'-10" Wide Cathedral Arch.....	15
5.2.2	18'-0" Tall x 8'-10" Wide Cathedral Arch.....	15
6	Recommendations	17
6.1	Inspection	17
6.1.1	3rd Avenue Tunnel.....	17
6.2	Repairs, Maintenance.....	17
6.2.1	3 rd Avenue Tunnel	17
6.2.2	I-94/2 nd Street Tunnel.....	18
7	References	21

List of Figures

Figure 1-1	Tunnel System Overview.....	1
Figure 3-1	Tunnel Outlet.....	9
Figure 3-2	Washington Avenue Shaft.....	10
Figure 3-3	Drift Tunnel and Ladder Access.....	10
Figure 6-1	Concrete Debris.....	18
Figure 6-2	Washington Avenue Shaft.....	18
Figure 6-3	Sediment Accumulation at Tunnel Outlet.....	19
Figure 6-4	Typical Void.....	20

List of Tables

Table 2-1	Typical Tunnel Cross Sections.....	4
Table 2-2	Typical Tunnel Cross Sections.....	5
Table 2-3	Typical Cross Sections.....	5
Table 2-4	Inspection History.....	6
Table 3-1	Summary of Tunnel Inspections.....	8
Table 3-2	USACE Mississippi River Middle Pool Drawdown Schedule.....	9
Table 5-1	I-94/2 nd Street Tunnel Defect Summary.....	13
Table 5-2	3 rd Avenue Tunnel Defect Summary.....	15

List of Appendices

Appendix A	System Overview
Appendix B	Tunnel Cross Sections
Appendix C	PACP Code Summary Charts
Appendix D	Inspection Data Tables
Appendix E	Tunnel Rating Figures

Certifications

I hereby certify that this report was prepared by me or under my direct supervision and that I am a duly Licensed Professional Engineer under the laws of the state of Minnesota.

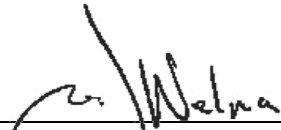

Joseph Welna
PE #: 49911

January 13, 2021

Date

1 Executive Summary

The Bassett Creek Watershed Management Commission (BCWMC) retained Barr Engineering Co. (Barr) to conduct an inspection of the 3rd Avenue tunnel and a portion of the I-94/2nd Street tunnel between the Mississippi River outlet and the junction with the 3rd Avenue tunnel in October 2020. The purpose of the inspection was to document current tunnel conditions and provide recommendations to BCWMC regarding future monitoring and repair.

The Bassett Creek tunnel system conveys the former open channel Bassett Creek through downtown Minneapolis to the Mississippi River where it discharges between the Upper and Lower St. Anthony Falls as shown in Figure 1-1. The tunnel system was constructed in three phases including the I-94/2nd Street tunnel (Phase 1 shown in green), the 3rd Avenue tunnel (Phase 2 shown in yellow), and the Double Box Culvert (Phase 3 shown in orange). The 2020 inspection extents performed for BCWMC are delineated with a red-dashed line. The portion of the I-94 tunnel upstream of the 3rd Avenue tunnel junction was inspected under a separate contract for the City of Minneapolis (City). The Double and Single Box Culverts (shown in orange) were inspected by Barr in October 2019. Findings from these inspections are documented in separate reports.



Figure 1-1 Tunnel System Overview

Further discussion and details regarding each tunnel and phase is provided in Section 2.

1.1 Recommendations

Based on the 2020 inspection findings, the following recommendations are provided to the BCWMC for consideration. Additional discussion regarding these recommendations is also provided in Section 6.

1.2 Inspection

The following provides recommendations to BCWMC regarding Barr's recommended inspection frequency for each tunnel segment.

1.2.1 3rd Avenue Tunnel

It is recommended that the BCWMC continue to perform a full NASSCO PACP inspection on a 5-year basis (coordinating with the City's I-94/2nd Street tunnel inspection).

1.3 Repairs, Maintenance

The following provides recommendation to BCWMC regarding Barr's recommended repairs and maintenance for each tunnel segment. Barr recommends that these repairs be performed in the next 10 years.

1.3.1 3rd Avenue Tunnel

Void Probing: The 2020 inspection did not include an assessment of void thicknesses behind the existing concrete tunnel liner and it is understood that no previous void investigations have been performed by others. It is recommended that void probing be performed to determine the presence of voids. This work could be coordinated with other repairs for to increase efficiency.

Infiltration Repair: Various degrees of infiltration were observed over the entire 3rd Avenue segment. Infiltration contributes to concrete degradation and encrustation buildup and can be a potential flow path that contributes to sandstone erosion outside of the tunnel. It is recommended that the points of infiltration be injected and sealed with chemical grout.

Debris Removal: Concrete debris was observed within the invert of the tunnel near the junction with the I-94 tunnel. It is recommended that this debris be removed to improve tunnel conveyance and to minimize trip hazards.

Washington Avenue Shaft Modification: The Washington Avenue Shaft is one of the primary access points to enter the Bassett Creek and the I-94/2nd Street tunnel system. The 8-foot-diameter shaft is approximately 70 feet deep and has an approximately 4-foot-deep sump at the bottom that is typically filled with water. This configuration adds challenges for access as well as safety hazards (i.e. submergence of inspectors). Barr recommends that a grated landing be installed to improve this access point for future inspections and maintenance..

1.3.2 I-94/2nd Street Tunnel

Outlet Sediment Removal: Sediment was observed blocking three of the four outlet bays in both the 2008 inspection, as well as the 2020 inspection, as shown in Figure 6-3. It is recommended that this sediment be removed within the tunnel outlet structure and immediately downstream of the outlet to improve tunnel conveyance.

Infiltration Repair: Various degrees of infiltration were observed over the entire I-94 tunnel segment. Infiltration contributes to concrete degradation and encrustation buildup and can be a potential flow path for eroded sandstone. It is recommended that the points of infiltration be injected and sealed with chemical grout.

Void Filling: The 2020 inspection did not include an assessment of void thicknesses behind the existing concrete tunnel liner. However, voids ranging from 0 feet to 0.9 feet were measured in 2008 by others (Ref. (1)). The presence of these voids likely does not present an immediate risk to the structural integrity of the tunnel; however, if left untreated, the voids may increase due to the friable nature of the sandstone which can be transported into the tunnel through points of infiltration which could lead to larger more significant problems including:

- **Tunnel Lining Failure:** The tunnel lining is unreinforced concrete and relies upon a solid contact with the surrounding sandstone to transfer surcharge loading. If this contact is lost, the tunnel lining can crack and ultimately fail. This is particularly important for the Cathedral Arch tunnel between station 23+70 to 64+94 which is unreinforced concrete.
- **Ground Loss and Sinkholes:** The St. Peter Sandstone formation is friable, and the development of large voids is a common occurrence outside of the deep stormwater tunnels in the Twin Cities region. If left untreated, these voids can increase and extend up to ground surface and cause ground loss or damage to infrastructure.

It is recommended that these voids be filled with grout to restore the outside tunnel lining contact, as well as close flow paths that lead to erosion and development of these voids.

2 Background

2.1 Tunnel System Construction Phases

Construction of the tunnel system was completed by the United States Army Corps of Engineers (USACE) and Minnesota Department of Transportation (MnDOT) between approximately 1979 and 1992 in three primary phases working downstream to upstream as shown in Figure A-1 of Appendix A.

2.1.1 Phase 1: I-94/2nd Street Tunnel

The I-94/2nd Street tunnel was constructed by the MnDOT in 1979. The tunnel was primarily constructed in St. Peter Sandstone approximately 60–100 feet below ground surface to convey Bassett Creek flows and stormwater runoff from Interstate 94 and 394. The tunnel is approximately 8,904 feet long and primarily runs below 2nd Street with typical cross sections as summarized in Table 2-1 from the 1977 plans (State Project 2781-122). The typical sections for the 2020 inspection intervals are graphically represented in Figures B-1 and B-2 in Appendix B.

Table 2-1 Typical Tunnel Cross Sections

Section	Station Interval	Shape	Dimensions	Notes
Section 1	18+54 to 19+53 (99 ft.)	Rectangle	Four 12-ft. tall chambers w/ varying width	Reinforced C.I.P. Concrete Outlet Structure
Section 2	19+53 to 23+25 (372 ft.)	Circular	12-ft diameter	Reinforced Precast Concrete (soft ground tunnel)
Section 3	23+25 to 23+70 (45 ft.)	Cathedral Arch	15'-6" tall by 10'-0" wide	Reinforced C.I.P. Concrete (w/ large adjacent void filling)
Section 4	23+70 to 64+94 (4,124 ft)	Cathedral Arch	15'-6" tall by 10'-0" wide	Unreinforced C.I.P. Concrete
Section 5	64+94 to 65+33 (39 ft.)	Wye Structure	Two chambers 10'-6" to 15'-6" tall, width varies	Reinforced C.I.P. Concrete
Section 6	65+33 to 69+75 (442 ft.)	Cathedral Arch	10'-6" tall by 9'-3" wide	Unreinforced Sodium Silicate or Shotcrete Spray (not part of Bassett Creek Tunnel)
Design 5 (not shown)	69+75 to 72+20 (245 ft.)	Circular	9-ft diameter	Reinforced C.I.P. (soft ground tunnel) (not part of Bassett Creek Tunnel)
Design 4B (not shown)	72+20 to 81+90 (970 ft.)	Cathedral Arch	10'-6" tall by 9'-3" wide	Unreinforced Sodium Silicate or Shotcrete Spray (not part of Bassett Creek Tunnel)
Design 7 (not shown)	81+90 to 107+58 (2,568 ft)	Circular	9-ft diameter	Reinforced C.I.P. (soft ground tunnel) Station 106+50 to 106+79 (precast concrete) (not part of Bassett Creek Tunnel)

2.1.2 Phase 2: 3rd Avenue Tunnel

The 3rd Avenue tunnel was constructed by the USACE in 1990. The tunnel was primarily constructed in St. Peter Sandstone approximately 70-80 feet below ground surface to convey Bassett Creek flow from the Double Box Culvert to the I-94/2nd Street tunnel. The 3rd Avenue tunnel is approximately 1,456 feet long and generally runs below 3rd Avenue. At station 115+10, the 3rd Avenue tunnel transitions to the Phase 3 Double Box Culvert through a larger tunnel section (section 7) and a deaeration chamber/drop structure (section 3). Although the deaeration chamber/drop structure was constructed as part of Phase 3, it is typically inspected as part of Phase 2. These sections are summarized in Table 2-1 from the 1990 plans (State Project 2789-51). The typical sections for the 2020 inspection intervals are graphically represented in Figures B-1 and B-2 in Appendix B.

Table 2-2 Typical Tunnel Cross Sections

Section	Station Interval	Shape	Dimensions	Notes
Section 6	100+54 to 115+10 (1,456 ft.)	Cathedral Arch	15'-0" tall by 8'-10" wide	Reinforced C.I.P. Concrete
Section 7	115+10 to 116+34 (124 ft.)	Cathedral Arch	18'-0" tall by 8'-10" wide	Reinforced C.I.P. Concrete (connection to 3 rd Avenue tunnel)
Drop Structure (not shown)	116+34 to 116+73 (39 ft.)	Rectangle	40-ft. tall by 20-ft. wide by 29'-1" drop	Reinforced C.I.P. Concrete (drop structure and deaeration chamber) (Constructed as part of Phase 3)

2.1.3 Phase 3: Double Box Culvert

The Double Box Culvert was constructed by the USACE in 1992 and was turned over to the local sponsor (City of Minneapolis) in 2002. The Double Box Culvert was constructed by open cut excavation 0–20 feet below ground surface and was designed to convey Bassett Creek flow to the 3rd Avenue tunnel. The Double Box Culvert is approximately 5,572 feet long and generally runs parallel with the Cedar Lake Trail. The Double Box Culvert primary cross sections are summarized in Table 2-3. This tunnel phase was not inspected as part of this project and the sections are not represented on the Appendix B figures.

Table 2-3 Typical Cross Sections

Station Interval	Shape	Dimensions	Notes
116+73 to 120+16 (343 ft.)	Single Box	11'-0" tall by 15'-0" wide	Reinforced C.I.P. Concrete
120+16 to 150+00 (2,984 ft.)	Double Box	11'-0" tall by 11'-0" wide	Reinforced C.I.P. Concrete

Station Interval	Shape	Dimensions	Notes
150+00 to 152+50 (250 ft.)	Double Box	11'-9" tall by 11'-0" wide	Reinforced C.I.P. Concrete
152+50 to 172+24 (1,974 ft.)	Double Box	11'-0" tall by 11'-0" wide	Reinforced C.I.P. Concrete
172+24 to 172+45 (21 ft.)	Flared Inlet Structure	varies	Reinforced C.I.P. Concrete

2.2 Inspection History

In accordance with the Operation and Maintenance Manual for the Bassett Creek Flood Control Project (Ref. (2)), the Double Box Culvert is on a 5-year inspection schedule and the I-94/2nd Street tunnel and 3rd Avenue tunnel are on 20-year inspection schedules. The BCWMC revised the I-94/2nd Street tunnel inspection to be on a 10-year schedule and the 3rd Avenue tunnel inspection to be on a 5-year schedule (to be coordinated with the Cities inspection of the I-94/2nd Street tunnel). The City of Minneapolis and/or MnDOT have also performed independent inspections of the Double Box Culvert, 3rd Avenue tunnel, and I-94/2nd Street tunnels.

The BCWMC typically coordinates the 5-year inspections with the City of Minneapolis and USACE staff. A history of the tunnel inspections is provided in Table 2-4. Inspection events that occurred with other entities (except for the 2008 MnDOT inspection) are not included in this summary.

Table 2-4 Inspection History

Date	Tunnel	Inspection Team	Recommendations	Notes
November 2004	Double Box Culvert	BCWMC (Barr)/City of Mpls.	Maintenance and repairs recommended, and later completed by the city of Minneapolis in January 2005.	First BCWMC post-construction inspection of Double Box Culvert. Findings are summarized in November 2004 memo (Ref. (3)).
April 2007	Double Box Culvert	BCWMC (Barr)/City of Mpls.	Maintenance and repairs recommended.	Pre-construction inspection between Sta. 119+00 and 130+00 prior to Target Field stadium construction. Findings are summarized in April 2007 memo (Ref. (4)).
February 2008	I-94/2nd Street Tunnel	MnDOT	Maintenance and repairs recommended.	Findings are summarized in August 2008 report (Ref. (1)).
February 2008	I-94/2nd Street Tunnel to 3 rd Ave. Connection, 3 rd Ave. Tunnel	BCWMC (Barr)/USACE/ City of Mpls.	Objective was to perform a visual inspection. No recommendations were made.	Findings are summarized in February 2008 memo (Ref. (5)).

Date	Tunnel	Inspection Team	Recommendations	Notes
November 2009	Double Box Culvert	BCWMC (Barr)/City of Mpls.	Recommendations to correspond with MN Ballpark authority to repair core hole through tunnel. Continued monitoring of tunnel defects.	Includes Target Field post-construction inspection. Findings are summarized in November 2008 memo (Ref. (6)).
December 2014	Double Box Culvert, 3 rd Ave. Tunnel, I-94/2 nd Street Tunnel	BCWMC (Barr)	Recommendations for ongoing monitoring and inspection were provided.	Findings are summarized in December 2014 report. I-94 tunnel was only inspected (Ref. (7)).
October 2019	Double Box Culvert	BCWMC (Barr)	Recommendations for maintenance repairs were identified.	Findings are summarized in June 2020 report. Inspection did not include single box culvert due to high flows which made approach to drop structure unsafe. (Ref. (9)).
October 2020	I-94/2 nd Street Tunnel (upstream of 3 rd Ave. Tunnel)	BCWMC (Barr)/City of Mpls.	Recommendations for maintenance repairs were identified.	Findings are summarized in report under development.
October 2020	I-94 Tunnel (downstream of 3 rd Ave. Tunnel) & 3 rd Avenue Tunnel	BCWMC (Barr)	Recommendations for maintenance repairs were identified.	Findings are summarized in this report.

3 2019 Inspection Summary

The I-94/2nd Street tunnel (downstream of the 3rd Avenue tunnel) and the 3rd Avenue tunnel were inspected over 2 days in October 2019. The inspections were conducted with a four-person team in the tunnel, with two people performing surface attendant duties. Tunnel stationing for observations was maintained using a measuring wheel. A summary of the inspection intervals and access points is provided in Table 3-1. Photos were taken during the inspections and are available upon request.

Table 3-1 Summary of Tunnel Inspections

Tunnel Segment	Inspection Date	Station Interval Inspected	Length Inspected (ft)	Primary Access/Egress	Emergency Access/Egress
I-94/2 nd Street Tunnel	10/6/20	18+54 to 51+50	3,296	Tunnel Outlet	Washington Ave Shaft
I-94/2 nd Street Tunnel	10/7/20	51+50 to 65+00	1,350	Washington Ave Shaft	Tunnel Outlet
3 rd Avenue Tunnel	10/7/20	100+53 to 116+34	1,581	Washington Ave Shaft	Tunnel Outlet

3.1 Access Considerations

Due to the depth of the tunnels and limited access points available, a safety standby contractor (Rescue Resources, Inc.) was onsite to assist with tunnel access and perform emergency rescue if required. In addition, a subcontracted crane with basket was positioned at the Washington Avenue shaft and was used for both primary and emergency access and egress. The following discussion presents access considerations for future tunnel inspections.

3.1.1 USACE Coordination

Inspection of the submerged portion of the I-94/2nd Street tunnel requires an approximate 12-foot drawdown of the Mississippi River middle pool normal pool (750 feet NGVD29) to elevation 738 feet by the USACE. Barr staff and the BCWMC administrator began correspondence with the USACE starting in 2017 to help facilitate the drawdown and inspection. Coordination continued with the USACE staff up until the 2020 inspection. One scheduled inspection was cancelled because of stakeholder comments received during the public comment period. Ultimately, the Bassett Creek tunnel inspection was scheduled and performed during the same drawdown period established by the USACE for its maintenance inspection of their lock and dam system. The BCWMC will likely need to coordinate future inspections to align with the USACE lock and dam inspection schedule. The drawdown schedule was communicated to the inspection team and is summarized in Table 3-2.

Table 3-2 USACE Mississippi River Middle Pool Drawdown Schedule

Date	Hour	Elevation (NGVD29)	Notes
Saturday, Oct. 3 rd	0700	750	Normal pool, drawdown starts
Sunday, Oct. 4 th	0700	746	
Monday, Oct. 5 th	0700	742	
Tuesday, Oct. 6 th	0700	738	Max drawdown, Inspection starts
Wednesday, Oct. 7 th	1700	738	End of drawdown, Inspection completed
Thursday, Oct. 8 th	1700	742	Drawdown was extended to Thursday to accommodate the tunnel inspection and additional lock and dam services.
Friday, Oct. 9 th	1700	746	
Saturday, Oct. 10 th	1700	750	Drawdown completed, normal operations

Leading up to the drawdown, Barr attended three virtual planning meetings with the drawdown stakeholders including the USACE, BCWMC, Xcel Energy, the University of Minnesota, Brookfield Renewables, Keystone Waters, MnDOT, and the National Park Service. During the inspection, Barr provided the lower lock operator with a 2-way radio for emergency communication, and provided updates to the operator regarding when the inspection started and ended each day. Barr also conducted a pre-inspection safety meeting with the USACE and inspection participants.

3.1.2 Tunnel Outlet

The tunnel outlet was the primary access and egress point for the first day of inspection. Access was achieved by walking around the fence (along Mill Ruins Park access road), down the riprap slope, and directly into the tunnel as shown in Figure 3-1. The water depth within the tunnel was approximately 2 feet for approximately the first 1,500 feet of tunnel.



Figure 3-1 Tunnel Outlet

3.1.3 Washington Avenue Shaft

The Washington Avenue shaft was the primary access and egress point for the second day of inspection. Access was achieved by crane and basket through an 8-foot-diameter, 70-foot-deep shaft. At the bottom of the shaft, there is a 4-foot-deep sump that prevents the basket from having a dry landing, so the basket must stay suspended, and swing towards a 6-foot-diameter drift tunnel for the inspector to exit the basket. Photos of the shaft entry are included in Figure 3-2.



Figure 3-2 Washington Avenue Shaft

Once the entrant exits the basket, they must traverse a 6-foot-diameter, 75-foot-long drift tunnel to where it connects with the 3rd Avenue tunnel approximately 7 to 8 feet below the drift tunnel. A ladder must be installed at the connection and secured to an existing eyebolt to enter the 3rd Avenue tunnel as shown in Figure 3-3.



Figure 3-3 Drift Tunnel and Ladder Access

4 NASSCO Rating System Definitions

Barr documented tunnel conditions using the 2016 Pipeline Assessment Certification Program (PACP) developed by The National Association of Sewer Service Companies (NASSCO) (Ref. (8)). PACP coding allows for standardized quantification of tunnel defects and observations. The following sections present a summary of the NASSCO PACP coding system and how it was used for the inspection.

4.1 PACP Categories

All observations, features, and defects fall under one of four categories:

1. Structural
2. Operations and maintenance
3. Construction features
4. Miscellaneous

A summary of the 2016 PACP codes arranged by category are provided in Appendix C for reference.

4.1.1 Structural Defects

The structural category of defects includes various types of defects where the tunnel liner has been damaged or is otherwise defective.

4.1.2 Operations and Maintenance Defects

The operations and maintenance category of defects includes infiltration and various types of foreign objects and material that are found in tunnels during inspections that may interfere with conveyance performance.

4.1.3 Construction Features

The construction feature codes describe conditions associated with the methods used to construct tunnels.

4.1.4 Miscellaneous Features

The miscellaneous codes include features and defects that are not included in the other categories.

4.2 PACP Condition Grades

Condition grades are assigned to the defects described above with grades ranging from 1-5 as summarized below:

- 1 – Minor Defect

-
- 2 – Minor to Moderate Defect
 - 3 - Moderate Defect
 - 4 - Significant Defect
 - 5 – Most Significant Defect

4.2.1 Grading of Continuous Defects

The PACP continuous defect feature is used to denote where any defect extends longitudinally for longer than 3 feet. However to develop a grade for the pipe segment, a mechanism is needed to translate a continuous defect into an equivalent number of point defects. The equivalent number (quantity) of “uninterrupted” continuous defects is calculated by dividing the length of the continuous defect by five.

5 Inspection Findings

This section presents the findings from the 2020 inspection. A comprehensive tabular record of the inspection is included in Appendix D. A summary of the quantity, type, and frequency of defects is presented and discussed. Lastly, a tunnel rating is provided for each tunnel cross section. The tunnel ratings were evaluated separately from both 1) Operations and Maintenance (O&M) and 2) Structural perspectives with defined below:

- Good: The tunnel liner is structurally adequate and defects are not causing deterioration. The tunnel requires monitoring but no maintenance or rehabilitation is currently necessary.
- Fair: The tunnel liner is structurally adequate but defects are causing deterioration. The tunnel requires monitoring, but no maintenance or rehabilitation is currently necessary.
- Poor: The tunnel liner is structurally inadequate and defects have caused advanced deterioration. The tunnel requires rehabilitation.
- Urgent: The tunnel liner is structurally inadequate or has a service-impending defect. The tunnel requires immediate rehabilitation.

5.1 I-94/2nd Street Tunnel

Table 5-1 provides a summary of the quantity of defects sorted by grade, as well as the O&M and Structural rating for each tunnel cross section. Figures that show the tunnel ratings graphically are included in Appendix E.

Table 5-1 I-94/2nd Street Tunnel Defect Summary

Tunnel Section	Station Interval	Grade 1 Defects	Grade 2 Defects	Grade 3 Defects	Grade 4 Defects	Grade 5 Defects	O&M Rating	Structural Rating
Outlet Structure	Sta. 18+54 to 19+53	0	0	0	11	0	Poor	Good
12' Diameter Circular	Sta. 19+53 to 23+25	97	37	11	0	0	Good	Fair
15'-6" Tall x 10'-0" Cathedral Arch	Sta. 23+25 to 64+94	514	1,290	58	32	31	Fair	Fair
Overall Tunnel	Sta. 18+54 to 64+94	611	1,327	69	43	31	Fair	Fair

Additional discussion for each cross section is provided below.

5.1.1 Outlet Structure

This 99-foot-long segment had the following defects:

- Grade 4: deposits settled fine (DSF)

Tunnel Rating Discussion:

- O&M Rating – Poor: This rating is the result of the continuous sediment buildup in three of the four outlet bays. The sediment buildup results in a significant reduction in stormwater conveyance capacity.
- Structural Rating – Good: Due to the buildup of sediment, detailed structural inspection could not be performed in three of the four bays. Inspection of the one open bay indicated the concrete to be in good structural condition.

5.1.2 12' Diameter Circular

This 372-foot-long segment had the following defects:

- Grade 1: deposits settled fine (DSF), circumferential crack (CC)
- Grade 2: crack longitudinal (CL), infiltration weeper
- Grade 3: multiple cracks (CM)

Tunnel Rating Discussion:

- O&M Rating – Good: There is approximately one point of infiltration for every 37 L.F. of tunnel, and the infiltration was of low severity, typically infiltration weepers (IW).
- Structural Rating – Fair: The most reoccurring defects in this segment are circumferential cracks (CC) and longitudinal cracks (CL). There is a CC approximately every 10 L.F. of tunnel and approximately 1 L.F. of longitudinal crack for every 3 L.F. of tunnel.

5.1.3 15'-6" Tall x 10'-0" Wide Cathedral Arch

This 4,169-foot-long segment had the following defects:

- Grade 1: circumferential crack (CC)
- Grade 2: crack spiral (CS), crack longitudinal (CL), infiltration weeper (IW), obstruction other (OBZ), deposits attached encrustation (DAE), surface aggregate visible (SAV), fracture circumferential (FC), hinge crack 2 (CH2)
- Grade 3: multiple cracks (CM), infiltration dripper (ID), tap break-in defective (TBD)
- Grade 4: infiltration runner (IR), surface aggregate missing (SAM)
- Grade 5: infiltration gusher (IG)

Tunnel Rating Discussion:

- O&M Rating – Fair: There is approximately one point of infiltration for every 8 L.F. of tunnel with severities ranging from infiltration weeper (IW) to infiltration gusher (IG).
- Structural Rating – Fair: The most reoccurring defects in this segment are circumferential cracks (CC) and longitudinal cracks (CL). There is a CC approximately every 9 L.F. of tunnel and approximately 1 L.F. of CL for every 1 L.F. of tunnel.

5.2 3rd Avenue Tunnel

Table 5-2 provides a summary of the quantity of defects sorted by grade, as well as the O&M and Structural rating for each tunnel cross section. Figures that show the tunnel ratings graphically are included in Appendix E.

Table 5-2 3rd Avenue Tunnel Defect Summary

Tunnel Section	Station Interval	Grade 1 Defects	Grade 2 Defects	Grade 3 Defects	Grade 4 Defects	Grade 5 Defects	O&M Rating	Structural Rating
15'-6" x 8'-10" Cathedral Arch	Sta. 100+54 to 115+10 (1,456 ft)	94	261	14	14	0	Fair	Good
18'-0" x 8'-10" Cathedral Arch	Sta. 115+10 to 116+34 (124 ft.)	1	23	0	0	0	Fair	Good
Overall Tunnel	Sta. 100+54 to 116+34 (1,580 ft)	95	284	14	14	0	Fair	Good

Additional discussion for each cross section is provided below.

5.2.1 15'-6" Tall x 8'-10" Wide Cathedral Arch

This 1,456-foot-long segment had the following defects:

- Grade 1: circumferential crack (CC)
- Grade 2: infiltration weeper (IW), deposits attached encrustation (DAE), obstruction other (OBZ)
- Grade 4: infiltration runner (IR)

Tunnel Rating Discussion:

- O&M Rating – Fair: There is approximately one point of infiltration for every 10 L.F. of tunnel with severities ranging from infiltration weeper (IW) to infiltration runner (IR).
- Structural Rating – Good to Fair: The most reoccurring defects in this segment are circumferential cracks (CC) and longitudinal cracks (CL). There is a CC approximately every 10 L.F. of tunnel and approximately 1 L.F. of CL for every 16 L.F. of tunnel. A significant number of cracks have been repaired and were coded as point patch repair (RPP) which do not impact the structural rating of the tunnel.

5.2.2 18'-0" Tall x 8'-10" Wide Cathedral Arch

This 124-foot-long segment had the following defects:

- Grade 1: circumferential crack (CC)
- Grade 2: infiltration weeper (IW), deposits attached encrustation (DAE)

Tunnel Rating Discussion:

- O&M Rating – Fair: There was notable development of deposits attached encrustation (DAE) throughout. Points of infiltration were difficult to identify due to the proximity to the drop structure and humid air. However, the prevalent deposits are an indication of infiltration.
- Structural Rating – Good to Fair: Formation of deposits typically occur at a liner defect such as a crack. Cracks were visible behind the deposits and were not coded. This is why a rating of good to fair is provided.

6 Recommendations

Based on the 2020 inspection findings, the following recommendations are provided to the BCWMC for consideration.

6.1 Inspection

The following provides recommendations to BCWMC regarding Barr's recommended inspection frequency for each tunnel segment.

6.1.1 3rd Avenue Tunnel

It is recommended that the BCWMC continue to perform a full NASSCO PACP inspection on a 5-year basis (coordinating with the City's I-94/2nd Street tunnel inspection).

6.2 Repairs, Maintenance

The following provides recommendation to BCWMC regarding Barr's recommended repairs and maintenance for each tunnel segment. Barr recommends that these repairs be performed in the next 10 years.

6.2.1 3rd Avenue Tunnel

Void Probing: The 2020 inspection did not include an assessment of void thicknesses behind the existing concrete tunnel liner and it is understood that no previous void investigations have been performed by others. It is recommended that void probing be performed to determine the presence of voids. This work could be coordinated with other repairs for to increase efficiency.

Infiltration Repair: Various degrees of infiltration were observed over the entire 3rd Avenue segment. Infiltration contributes to concrete degradation and encrustation buildup and can be a potential flow path that contributes to sandstone erosion outside of the tunnel. It is recommended that the points of infiltration be injected and sealed with chemical grout.

Debris Removal: Concrete debris was observed within the invert of the tunnel near the junction with the I-94 tunnel as shown in Figure 6-1. It is recommended that this debris be removed to improve tunnel conveyance and to minimize trip hazards.



Figure 6-1 Concrete Debris

Washington Avenue Shaft Modification: The Washington Avenue Shaft is one of the primary access points to enter the Bassett Creek and the I-94/2nd Street tunnel system. The 8-foot-diameter shaft is approximately 70 feet deep and has an approximately 4-foot-deep sump at the bottom that is typically filled with water. This configuration adds challenges for access as well as safety hazards (i.e. submergence of inspectors). Barr recommends that a grated landing be installed to improve this access point for future inspections and maintenance. A photo showing the bottom of the existing shaft is included in Figure 6-2.



Figure 6-2 Washington Avenue Shaft

6.2.2 I-94/2nd Street Tunnel

Outlet Sediment Removal: Sediment was observed blocking three of the four outlet bays in both the 2008 inspection, as well as the 2020 inspection, as shown in Figure 6-3. It is recommended that this sediment be removed within the tunnel outlet structure and immediately downstream of the outlet to improve tunnel conveyance.



Figure 6-3 Sediment Accumulation at Tunnel Outlet

Infiltration Repair: Various degrees of infiltration were observed over the entire I-94 tunnel segment. Infiltration contributes to concrete degradation and encrustation buildup and can be a potential flow path for eroded sandstone. It is recommended that the points of infiltration be injected and sealed with chemical grout.

Void Filling: The 2020 inspection did not include an assessment of void thicknesses behind the existing concrete tunnel liner. However, voids ranging from 0 feet to 0.9 feet were measured in 2008 by others (Ref. (1)). The presence of these voids likely does not present an immediate risk to the structural integrity of the tunnel; however, if left untreated, the voids may increase due to the friable nature of the sandstone which can be transported into the tunnel through points of infiltration which could lead to larger more significant problems including:

- **Tunnel Lining Failure:** The tunnel lining is unreinforced concrete and relies upon a solid contact with the surrounding sandstone to transfer surcharge loading. If this contact is lost, the tunnel lining can crack and ultimately fail. This is particularly important for the Cathedral Arch tunnel between station 23+70 to 64+94 which is unreinforced concrete.
- **Ground Loss and Sinkholes:** The St. Peter Sandstone formation is friable, and the development of large voids is a common occurrence outside of the deep stormwater tunnels in the Twin Cities region. If left untreated, these voids can increase and extend up to ground surface and cause ground loss or damage to infrastructure.

It is recommended that these voids be filled with grout to restore the outside tunnel lining contact, as well as close flow paths that lead to erosion and development of these voids. A photo of a typical void above a similar stormwater tunnel in Minneapolis is provided in Figure 6-4 for reference.



Figure 6-4 Typical Void

7 References

1. **CNA Consulting Engineers.** I-94 Storm Tunnel System Assessment Report. Prepared for Minnesota Department of Transportation. July 2008.
2. **AUTHOR.** Operation and Maintenance Manual for the Bassett Creek Flood Control Project. XX XXXX.
3. **Barr Engineering Co.** Memorandum: Double Box Culvert Inspection-Bassett Creek Flood Control Project. Inspection Date: November 9, 2004. 2004.
4. —. Memorandum: Bassett Creek Double Box Culvert Preconstruction Inspection-Proposed Twins Stadium Site. Inspection Date: April 29, 2007. Prepared for Bassett Creek Watershed Management Commission. 2007.
5. —. Memorandum: Second Street Tunnel and Third Avenue Tunnel Inspection, Inspection Date: February 20, 2008. Prepared for Bassett Creek Watershed Management Commission. 2008.
6. —. Memorandum: Bassett Creek Double Box Culvert 5-Year Inspection. Inspection Date: November 19, 2009. Prepared for Bassett Creek Watershed Management Commission. 2009.
7. —. Bassett Creek Double Box Culvert and 3rd Avenue Tunnel Inspection Report. Inspection Date: December 2014. Prepared for the City of Minneapolis & Bassett Creek Watershed Mngement Commission. March 2016.
8. **NASSCO.** Pipeline Assessment Certification Program. *Reference Manual 7.0.2.* September 2016.
9. **Barr Engineering Co.** Bassett Creek Double Box Culvert Inspection Report. Inspection Date: October 2019. Prepared for the Bassett Creek Watershed Mngement Commission. October 2019.

Appendix A

System Overview

Barr Footer: ArcGIS 10.7.1, 2021-01-07 13:50 File: I:\Client\BassettCreek\Work_Orders\2020\3rd Avenue Tunnel and I-94\2nd St. Tunnel Inspections\Fig A-1 2020 3rd Avenue Tunnel and I-94 2nd St. Tunnel Inspection.mxd User: cm13



- ⊕ Stationing
- Phase 1: I-94/2nd Street Tunnel
- Phase 2: 3rd Avenue Tunnel
- Phase 3: Double Box Culvert
- - - 2020 Inspection Extent

Notes:
 1. The portion of the I-94/2nd Street Tunnel upstream of the junction with the 3rd Avenue Tunnel was inspected under a separate project in 2020, and findings are included in a separate report.

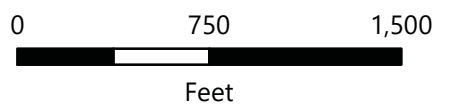

SYSTEM OVERVIEW
 2020 3rd Avenue Tunnel &
 I-94/2nd St. Tunnel Inspection
 Performed for the Bassett Creek
 Watershed Management Commission

FIGURE A-1



Aerial Image: USDA FSA 2019

Appendix B

Tunnel Cross Sections

Barr Footer: ArcGIS 10.7.1, 2021-01-07 14:09 File: I:\Client\BassettCreek\Work_Orders\2020\3rd Avenue Tunnel and I-94\2nd St. Tunnel Inspections\Fig B-1 Typical Sections.mxd User: cm13

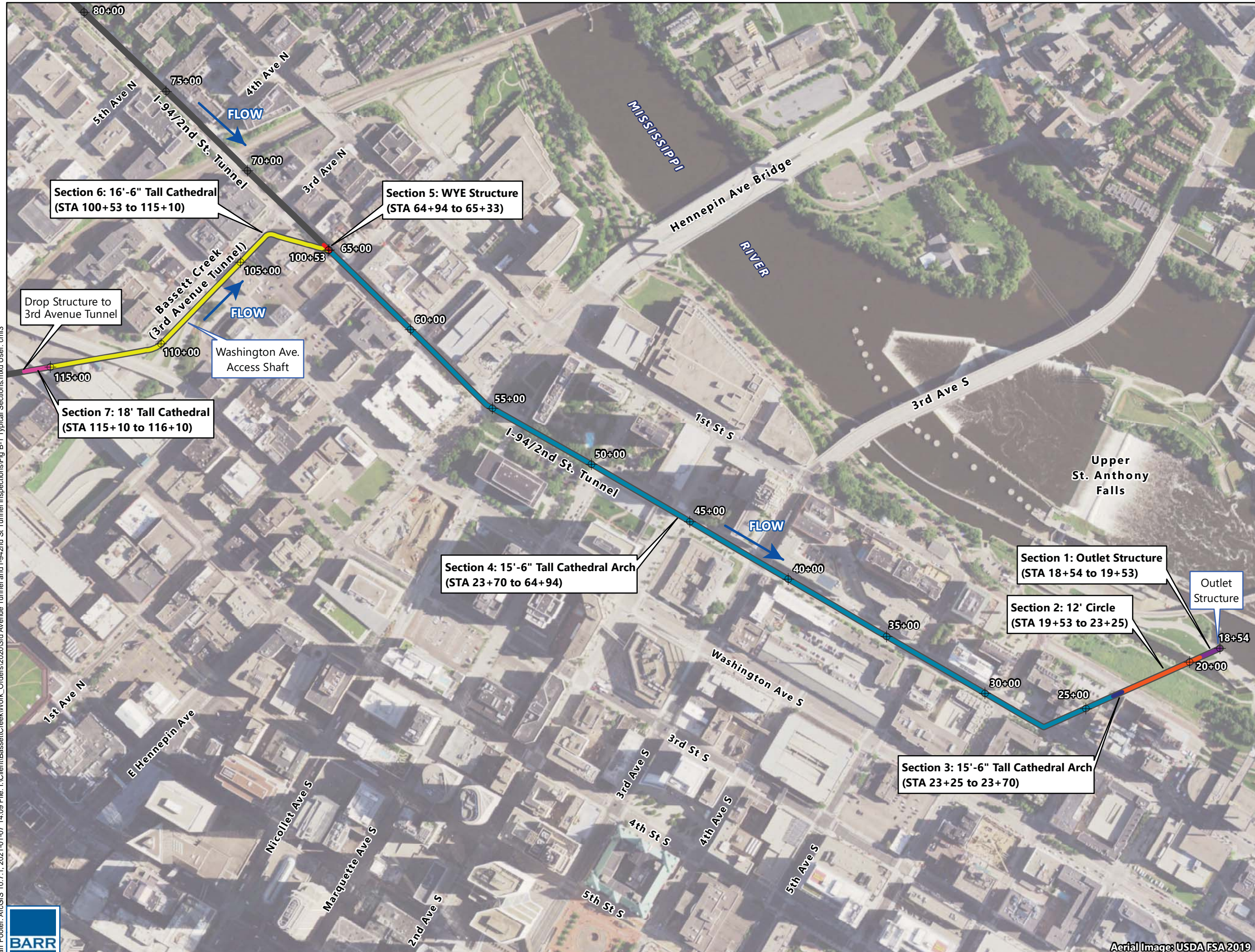

⊕ Stationing
— Tunnel Alignment (Colors indicate typical sections)

- Notes:
- 1. The portion of the I-94/2nd Street Tunnel upstream of the junction with the 3rd Avenue Tunnel was inspected under a separate project in 2020, and findings are included in a separate report.
 - 2. See Figure B-2 for typical sections.

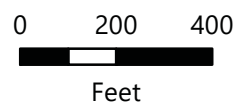

TYPICAL SECTIONS
2020 3rd Avenue Tunnel & I-94/2nd St. Tunnel Inspection
Performed for the Bassett Creek Watershed Management Commission

FIGURE B-1



Aerial Image: USDA FSA 2019

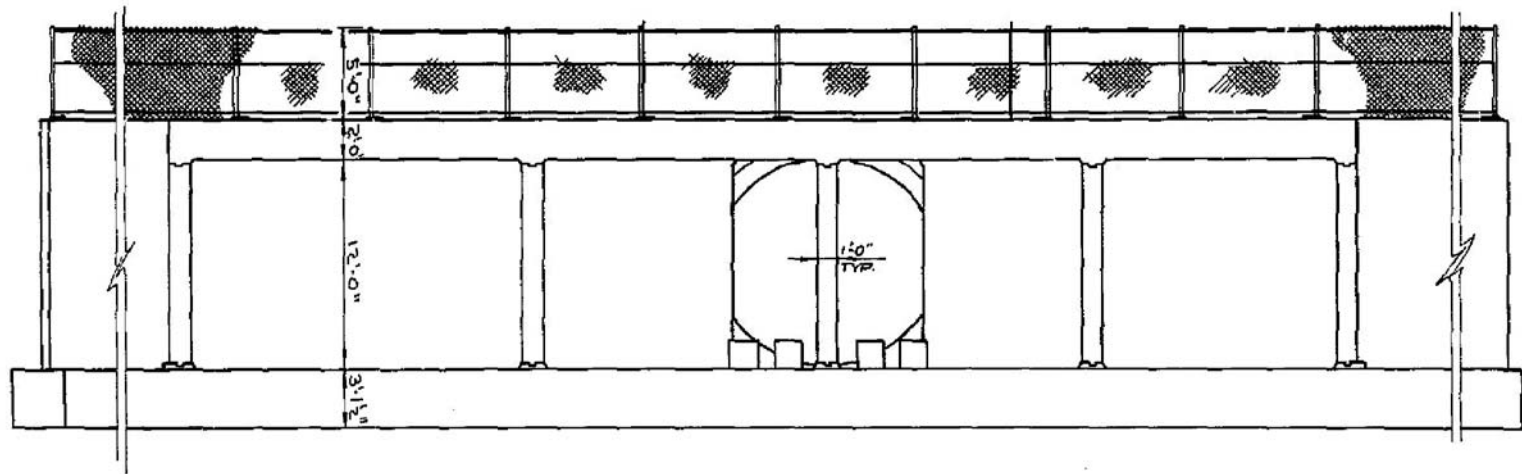

Section 1: Outlet Structure (Elevation View)
(STA 18+54 to 19+53)

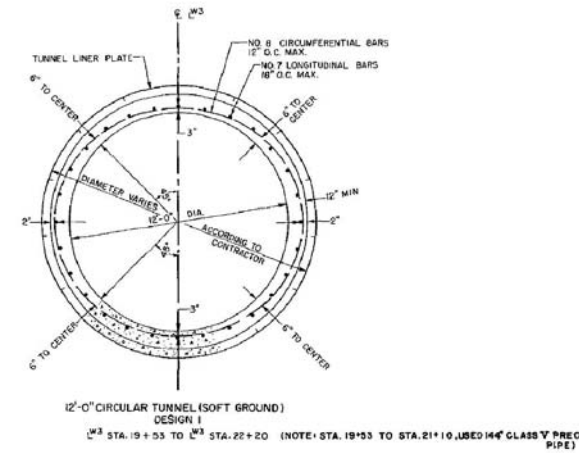

Section 2: Design 1 - 12' Circle
(STA 19+53 to 23+25)

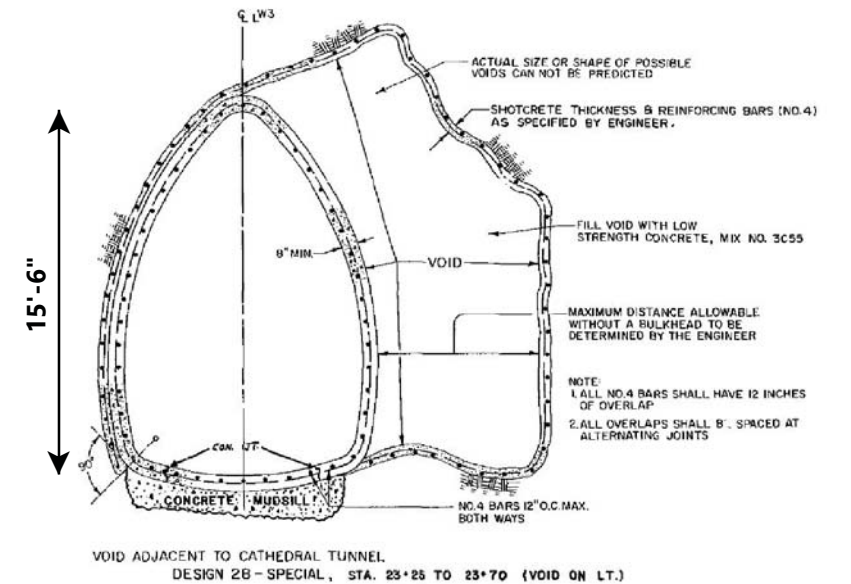

Section 3 - Design 2B Special- 15'6" Tall Cathedral Arch
(STA 23+25 to 23+70)

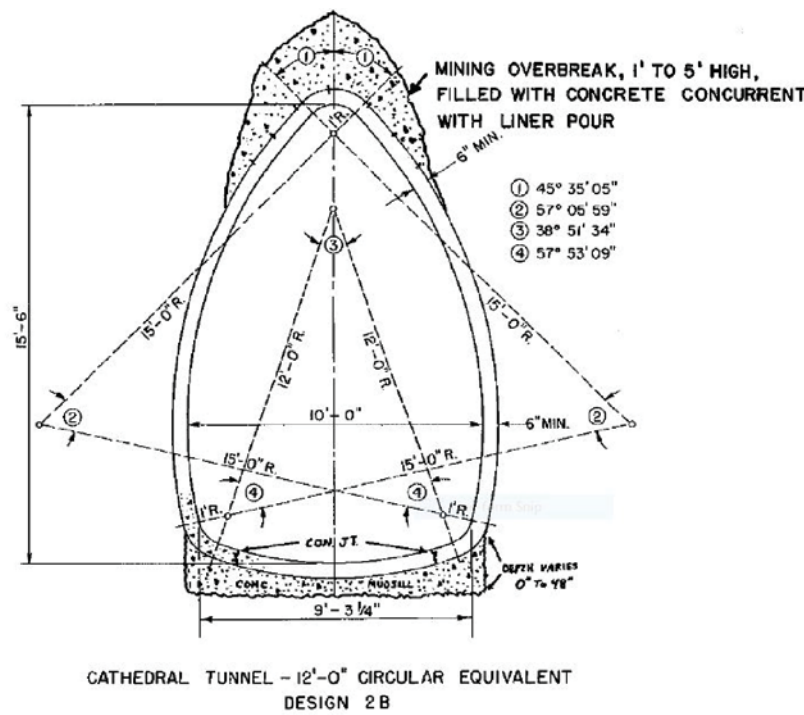

Section 4 - Design 2B- 15'6" Tall Cathedral Arch
(STA 23+70 to 64+94)

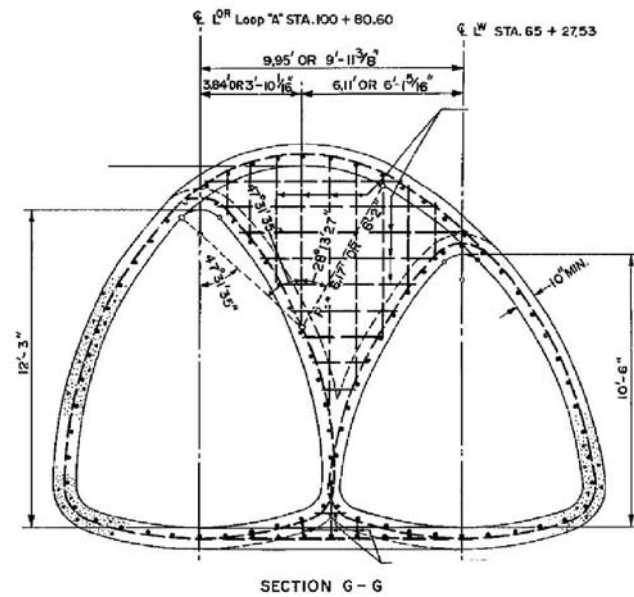

Section 5 - WYE Structure- Section Varies
(STA 64+94 to 65+33)

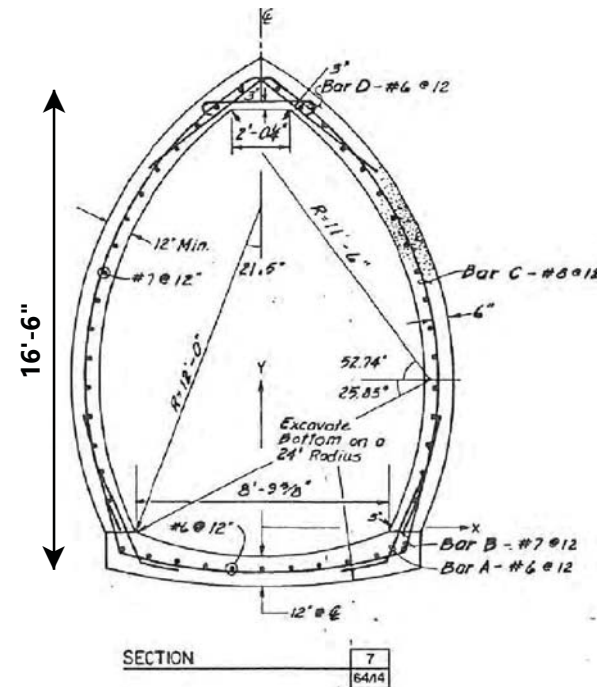

Section 6 - 16'6" Tall Cathedral- Section Varies
(STA 100+53 to 115+10)

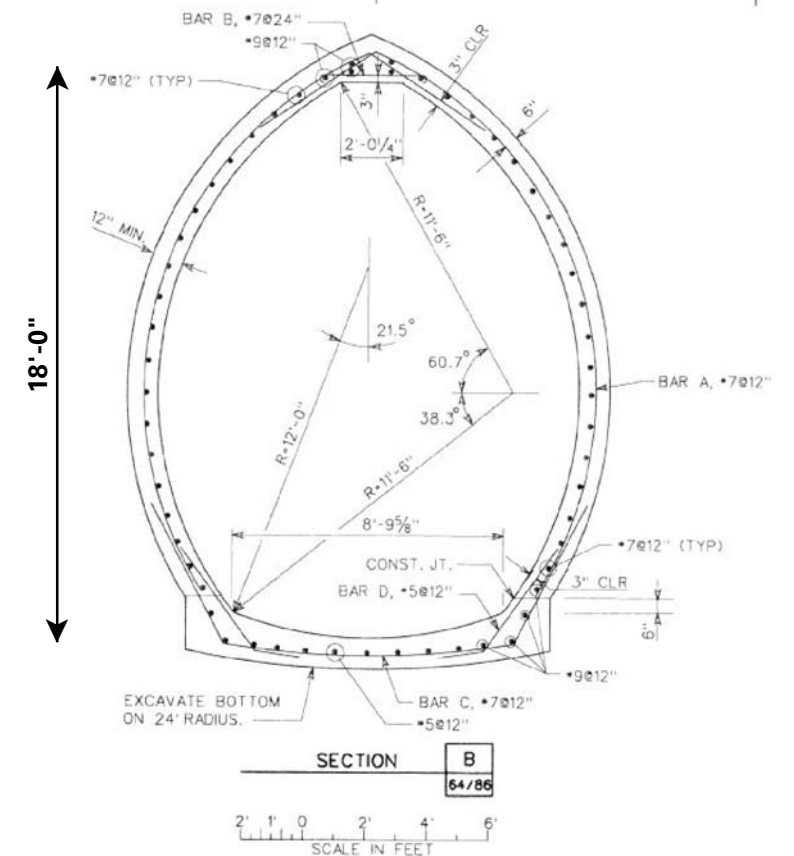

Section 7 - 18' Tall Cathedral
(STA 115+10 to 116+10)

Notes:
1. Sections are not to scale and are for illustrative purposes only.

TYPICAL SECTIONS
2020 3rd Avenue Tunnel & I-94/2nd St. Tunnel Inspection
Performed for the Bassett Creek Watershed Management Commission

FIGURE B-2

Barr Footer: ArcGIS 10.7.1, 2021-01-07 13:45 File: I:\Client\BassettCreek\Work_Orders\2020\3rd Avenue Tunnel and I-94\2nd St. Tunnel Inspection\Fig B-2 Typical Section Diagrams.mxd User: cm13

Appendix C

PACP Code Summary Charts



Figure C-1

NASSCO'S PIPELINE ASSESSMENT CERTIFICATION PROGRAM® (PACP®)

Section 4 — Structural Defect Coding

C CRACK 4-3 CL Longitudinal CC Circumferential CM Multiple CS Spiral CH Hinge (2, 3, 4)	F FRACTURE 4-9 FL Longitudinal FC Circumferential FM Multiple FS Spiral FH Hinge (2, 3, 4)	B BROKEN 4-17 BSV Soil Visible BVV Void Visible	H HOLE 4-21 HSV Soil Visible HVV Void Visible	D DEFORMED 4-25 (Rigid) DR Deformed Rigid No modifiers used.	D DEFORMED 4-25 (Flexible) DFBR Bulging Round DFBI Bulging Inv.Curv. DFC Creasing DFE Elliptical	D DEFORMED 4-25 (Brick) DTBR Bulging Round DTBI Bulging Inv.Curv.
X COLLAPSE 4-37 X Collapse No descriptors and no modifiers used.	J JOINT 4-43 JOS Offset Small JOM Offset Medium JOL Offset Large	J JOINT 4-43 JOSD Offset Small Defect JOMD Offset Medium Defect JOLD Offset Large Defect	J JOINT 4-43 JSS Separation Small JSM Separation Med. JSL Separation Large	J JOINT 4-43 JAS Angular Small JAM Angular Medium JAL Angular Large	S SURFACE 4-51 DAMAGE SRI Roughness Increased SAV Aggregate Visible SAP Aggregate Projecting SAM Aggregate Missing	S SURFACE 4-51 DAMAGE SRV Reinforcement Visible SRP Reinforcem.Projecting SRC Reinforcem.Corroded SMW Missing Wall
S SURFACE 4-51 DAMAGE SSS Surface Spalling SSC Surface Spalling Coating SCP Chemical Attack SZ Other	LF LINING 4-67 FEATURES LFAC Abdn'd Connection LFAS Annular Space LFB Blistered Lining LFCS Service Cut Shifted	LF LINING 4-67 FEATURES LFD Detached LFDC Discoloration LFDE Defective End LFDL Delamination	LF LINING 4-67 FEATURES LFOC Overcut Service LFRS Resin Slug LFUC Undercut Service LFW Wrinkled LFZ Other	WF WELD 4-85 FAILURE WFC Circumferential WFL Longitudinal WFM Multiple WFS Spiral WFZ Other	RP POINT REPAIR 4-89 RPL Liner RPLD Liner Defective RPP Patch RPPD Patch Defective	RP POINT REPAIR 4-89 RPR Replacement RPRD Replmt. Defective RPZ Other RPZD Other Defective
BRICKWORK 4-97 DB Displaced MB Missing DI Dropped Invert	BRICKWORK 4-97 MMS Mortar Missing Small MMM Mortar Missing Med. MML Mortar Missing Large					



Figure C-2

NASSCO'S PIPELINE ASSESSMENT CERTIFICATION PROGRAM® (PACP)®

Section 5 — Operation and Maintenance

D DEPOSITS 5-3 (Attached) DAE Encrustation DAGS Grease DAR Ragging DAZ Other	D DEPOSITS 5-4 (Settled) DSF Fine DSGV Gravel DSC Hard/Compact DSZ Other	D DEPOSITS 5-4 (Ingress) DNF Fine (silt/sand) DNGV Gravel DNZ Other	R ROOTS 5-11 (Fine) RFB Barrel RFL Lateral RFC Connection RFJ Joint	R ROOTS 5-11 (Medium) RMB Barrel RML Lateral RMC Connection RMJ Joint	R ROOTS 5-11 (Ball) RBB Barrel RBL Lateral RBC Connection RBJ Joint	R ROOTS 5-11 (Tap) RTB Barrel RTL Lateral RTC Connection RTJ Joint
I INFILTRATION 5-19 IS Stain ISB Barrel ISC Connection ISJ Joint ISL Lateral	I INFILTRATION 5-19 IW Weeper IWB Barrel IWC Connection IWJ Joint IWL Lateral	I INFILTRATION 5-19 ID Dripper IDB Barrel IDC Connection IDJ Joint IDL Lateral	I INFILTRATION 5-19 IR Runner IRB Barrel IRC Connection IRJ Joint IRL Lateral	I INFILTRATION 5-19 IG Gusher IGB Barrel IGC Connection IGJ Joint IGL Lateral	OB OBSTACLES 5-31 OBSTRUCTIONS OBB Brick or Masonry OBC Object Through Connection OBI Object Intruding Through Wall	OB OBSTACLES 5-31 OBSTRUCTIONS OBJ Object in Joint OBM Pipe Material in Invert OBN Construction Debris OBP External Pipe Cable
OB OBSTACLES 5-31 OBSTRUCTIONS OBR Rocks OBS Built In Structure OBZ Other	V VERMIN 5-45 VR Rat VC Cockroach VZ Other	G GROUT TEST 5-49 & SEAL GTP Grout Test Passed GTPJ Joint GTPL Lateral GTF Grout Test Failed GTFJ Joint GTFL Lateral	G GROUT TEST 5-49 & SEAL GTU Grout Test Unable GTUJ Joint GTUL Lateral GRT Grout Test Location			

Section 6 — Construction Features

T TAP 6-3 TB Break-In/Hammer TBI Intruding TBD Defective TBC Capped TBA Activity TBB Abandoned	T TAP 6-3 TF Factory Made TFI Intruding TFD Defective TFC Capped TFA Activity TFB Abandoned	T TAP 6-3 TR Rehabilitated TRI Intruding TRD Defective TRC Capped TRA Activity TRB Abandoned	T TAP 6-3 TS Saddle TSI Intruding TSD Defective TSC Capped TSA Activity TSB Abandoned	IS INTRUDING SEALING MATERIAL 6-15 ISSR Sealing Ring ISSRB Broken ISSRH Hanging ISSRL Loose ISGT Grout ISZ Other	M MISCELLANEOUS FEATURES 7-1 MCU Camera Underwater MGO General Observation MGP General Photograph MJL Joint Length	
L LINE (of sewer) 6-21 LD Down LL Left LLD Left Down LLU Left Up	L LINE (of sewer) 6-21 LR Right LRD Right Down LRU Right Up LU Up	A ACCESS POINT 6-25 ACB Catch Basin ACO Cleanout ACOM Mainline ACOP Property ACOH House	A ACCESS POINT 6-25 ADP Discharge Point AEP End of Pipe AJB Junction Box AM Meter AMH Manhole	A ACCESS POINT 6-25 AOC Other Structure ATC Tee Connection AWA Wastewater Access AWW Wetwell AZ Other	M MISCELLANEOUS FEATURES 7-1 MLC Lining Change MMC Material Change MSC Shape/Size Change MSA Survey Abandoned MWL Water Level	M MISCELLANEOUS FEATURES 7-1 MWLS Water Level Sag MWM Water Mark MY Dye Test MYV Dye Visible MYN Not Visible

Section 7 — Miscellaneous Features

Appendix D

Inspection Data Tables

3rd Avenue Tunnel

Inspection Notes - Station 100+53 to 116+10

Begin Station	End Station	Code	Family	Rating	Clock From	Clock To	Length (ft.)	Percent (%)	Comment
100+53		MGO	Misc.	0			0		Start of 3rd Ave. Tunnel
100+53	100+66	CS	Struct.	2	8	11	13		
100+63	100+70	CL	Struct.	2	7		7		
100+71		IR	O&M	4	9	11	0		
100+73		CC	Struct.	1	7	11	0		
100+80		RPP	Struct.	0	12	12	0		Circular Patch 6' - 10' dia.
100+80	116+10	RPP	Struct.	0	12		1530		6" dia. patched grout hole, every ~ 10' at 12 o'clock
100+88		MGO	Misc.	0	6		0		4' dia. circular concrete debris
101+00		MGO	Misc.	0	6		0		4' dia. circular concrete debris
100+89		CC	Struct.	1	7	9	0		
100+89		IW	O&M	2	7	9	0		
100+89	101+00	CS	Struct.	2	8	10	11		
100+94		CC	Struct.	1	9	4	0		
101+00	101+06	CS	Struct.	2	8	9	6		
101+05		MSC	Misc.	0			0		End of wye transition.
101+05		CC	Struct.	1	7	5	0		
101+05		IS	O&M	0	7	5	0		
101+16		CC	Struct.	1	3	5	0		
101+20		CC	Struct.	1	7	9	0		
101+20		IW	O&M	2	7	9	0		
101+20		CC	Struct.	1	3	5	0		
101+20		IW	O&M	2	3	5	0		
101+20	101+25	CS	Struct.	2	8	11	5		
101+25		CC	Struct.	1	7	9	0		
101+26		CC	Struct.	1	8	5	0		
101+26		ID	O&M	3	2		0		
101+33		CC	Struct.	1	7	9	0		
101+33		CC	Struct.	1	4	5	0		
101+45		CC	Struct.	1	12	5	0		

*Defect ratings of 4 and 5 are shaded orange and red respectively.

3rd Avenue Tunnel

Inspection Notes - Station 100+53 to 116+10

Begin Station	End Station	Code	Family	Rating	Clock From	Clock To	Length (ft.)	Percent (%)	Comment
101+45		IW	O&M	2	12	5	0		
101+45	101+48	CS	Struct.	2	3	5	3		
101+52	101+55	CS	Struct.	2	12	5	3		
101+52		IR	O&M	4	4		0		
101+53		CC	Struct.	1	7	10	0		
101+53		IW	O&M	2	7	10	0		
101+60		CC	Struct.	1	7	9	0		
101+60		IS	O&M	0	7	9	0		
101+60		CC	Struct.	1	4	5	0		
101+60		IW	O&M	2	4	5	0		
101+64		CC	Struct.	1	7	8	0		
101+64		IW	O&M	2	7	8	0		
101+73		CC	Struct.	1	11	3	0		
101+75		CC	Struct.	1	7	5	0		
101+75		IW	O&M	2	7	5	0		
101+80		MGO	Misc.	0			0		4' dia. circular concrete debris
101+88		CC	Struct.	1	7	10	0		
101+93		MGO	Misc.	0			0		4' dia. circular concrete debris
101+93		IW	O&M	2	5		0		
102+00		MGO	Misc.	0			0		4' dia. circular concrete debris
102+08		CC	Struct.	1	2	5	0		
102+08		IR	O&M	4	3		0		
102+12		CC	Struct.	1	7	5	0		
102+12		IW	O&M	2	7	5	0		
102+17	102+23	CS	Struct.	2	7	9	6		
102+17	102+23	CS	Struct.	2	1	5	6		
102+27		CC	Struct.	1	7	5	0		
102+27		IW	O&M	2	7	5	0		
102+30		CC	Struct.	1	8	5	0		

*Defect ratings of 4 and 5 are shaded orange and red respectively.

3rd Avenue Tunnel

Inspection Notes - Station 100+53 to 116+10

Begin Station	End Station	Code	Family	Rating	Clock From	Clock To	Length (ft.)	Percent (%)	Comment
102+30		IW	O&M	2	8	5	0		
102+40	102+44	CS	Struct.	2	7	5	4		
102+54		CC	Struct.	1	7	10	0		
102+54		IW	O&M	2	7	10	0		
102+54		CC	Struct.	1	3	5	0		
102+54		IW	O&M	2	3	5	0		
102+66		CC	Struct.	1	7	5	0		
102+66		IR	O&M	4	2		0		
102+72		CC	Struct.	1	11	3	0		
102+72		ID	O&M	3	12		0		
102+75	102+80	CL	Struct.	2	8		5		
102+80		CC	Struct.	1	7	11	0		
102+80		CC	Struct.	1	4	5	0		
102+88		RPP	Struct.	0	10	4	0		
102+94		CC	Struct.	1	7	5	0		
102+94		IW	O&M	2	7	5	0		
103+10		CC	Struct.	1	7	5	0		
103+13		CC	Struct.	1	7	5	0		
103+13		IW	O&M	2	7	5	0		
103+13	103+16	CS	Struct.	2	7	5	3		
D LINE LEFT		XXX	#N/A	#N/A	13	13	0		
103+23		CC	Struct.	1	7	11	0		
103+23		IW	O&M	2	7	11	0		
103+24		CC	Struct.	1	6	8	0		
103+30		CC	Struct.	1	1	5	0		
103+30		IW	O&M	2	1	5	0		
103+35		RPP	Struct.	0	7	1	0		
103+39		CC	Struct.	1	7	9	0		
103+45	103+49	CS	Struct.	2	7	5	4		

*Defect ratings of 4 and 5 are shaded orange and red respectively.

3rd Avenue Tunnel

Inspection Notes - Station 100+53 to 116+10

Begin Station	End Station	Code	Family	Rating	Clock From	Clock To	Length (ft.)	Percent (%)	Comment
103+48		CC	Struct.	1	4	5	0		
103+52	103+58	CS	Struct.	2	2	4	6		
103+52	103+55	CL	Struct.	2	9		3		
103+63	103+70	CS	Struct.	2	7	10	7		
103+71	103+80	CS	Struct.	2	7	10	9		
103+71		CC	Struct.	1	7	5	0		
103+75		RPP	Struct.	0	12		0		
103+83		CC	Struct.	1	8	4	0		
104+00		CC	Struct.	1	7	11	0		
104+00		IW	O&M	2	7	11	0		
104+10		CC	Struct.	1	2	5	0		
104+10		IW	O&M	2	2	5	0		
104+16	104+20	CS	Struct.	2	7	10	4		
104+20	104+23	CS	Struct.	2	7	10	3		
104+20	104+23	CS	Struct.	2	2	5	3		
104+30		ID	O&M	3	12		0		
104+30		CC	Struct.	1	7	5	0		
104+35		RPP	Struct.	0	12		0		
104+42		CC	Struct.	1	7	12	0		
104+44		RPP	Struct.	0	12		0		
104+44		CC	Struct.	1	11	1	0		
104+50		CC	Struct.	1	7	10	0		
104+50		IW	O&M	2	7	10	0		
104+53	104+65	CS	Struct.	2	7	5	12		
104+53		IW	O&M	2	7	8	0		
104+70		CC	Struct.	1	12	5	0		
104+76		RPP	Struct.	0	12		0		
104+76		CC	Struct.	1	8	12	0		
104+76		IW	O&M	2	5		0		

*Defect ratings of 4 and 5 are shaded orange and red respectively.

3rd Avenue Tunnel

Inspection Notes - Station 100+53 to 116+10

Begin Station	End Station	Code	Family	Rating	Clock From	Clock To	Length (ft.)	Percent (%)	Comment
104+84		RPP	Struct.	0	12		0		
104+87		CC	Struct.	1	7	8	0		
104+87		CC	Struct.	1	3	4	0		
104+94		CC	Struct.	1	3	5	0		
104+94		IW	O&M	2	3	5	0		
104+94		CC	Struct.	1	7	9	0		
104+94		IW	O&M	2	7	9	0		
105+02		CC	Struct.	1	7	11	0		
105+02		IW	O&M	2	7	11	0		
105+02		CC	Struct.	1	1	5	0		
105+02		IW	O&M	2	1	5	0		
105+08		RPP	Struct.	0	12		0		
105+09		CC	Struct.	1	7	10	0		
105+09		IW	O&M	2	7	10	0		
105+18		RPP	Struct.	0	12		0		
105+18		CC	Struct.	1	7	8	0		
105+24		CC	Struct.	1	3	5	0		
105+24		IR	O&M	4	4		0		
105+26	105+58	CS	Struct.	2	10	5	32		
105+38		CC	Struct.	1	7	5	0		
105+38		IW	O&M	2	5		0		
105+43	105+46	CS	Struct.	2	2	5	3		
105+47		IR	O&M	4	4		0		
105+48		RPP	Struct.	0	12		0		
105+51		CC	Struct.	1	7	4	0		
105+59	105+63	IW	O&M	2	3		4		
105+63		IR	O&M	4	3		0		
105+63		CC	Struct.	1	2	5	0		
105+81	105+87	CS	Struct.	2	7	3	6		

*Defect ratings of 4 and 5 are shaded orange and red respectively.

3rd Avenue Tunnel

Inspection Notes - Station 100+53 to 116+10

Begin Station	End Station	Code	Family	Rating	Clock From	Clock To	Length (ft.)	Percent (%)	Comment
105+82		CC	Struct.	1	3	4	0		
105+88	105+94	CS	Struct.	2	7	5	6		
105+88		IW	O&M	2	3	8	0		
106+02		CC	Struct.	1	8	5	0		
106+02		IR	O&M	4	2		0		
106+04		IR	O&M	4	9		0		
106+10		CC	Struct.	1	7	5	0		
106+17	106+29	CL	Struct.	2	9		12		
106+28		CC	Struct.	1	7	5	0		
106+28		ID	O&M	3	12		0		
106+32		CC	Struct.	1	1	3	0		
106+38	106+46	CS	Struct.	2	7	5	8		
106+38	106+46	IW	O&M	2	7	5	8		
106+49		CC	Struct.	1	7	5	0		
106+49		IW	O&M	2	7	5	0		
106+60		AMH	Const.	0	10		0		Lateral pipe to Washington Ave. Shaft
106+72		CC	Struct.	1	7	5	0		
106+72		IW	O&M	2	7	5	0		
106+72		DAE	O&M	2	7	9	0		
106+77	106+84	CS	Struct.	2	7	9	7		
106+84		CC	Struct.	1	7	8	0		
106+84		IW	O&M	2	7	8	0		
106+84		CC	Struct.	1	1	5	0		
106+84		IW	O&M	2	1	5	0		
106+96	107+01	CS	Struct.	2	8	3	5		
107+01	107+05	CL	Struct.	2	3		4		
107+12		CC	Struct.	1	9	1	0		
107+17	107+22	CS	Struct.	2	7	11	5		
107+17	107+22	IW	O&M	2	7	11	5		

*Defect ratings of 4 and 5 are shaded orange and red respectively.

3rd Avenue Tunnel

Inspection Notes - Station 100+53 to 116+10

Begin Station	End Station	Code	Family	Rating	Clock From	Clock To	Length (ft.)	Percent (%)	Comment
107+27	107+30	CS	Struct.	2	8	4	3		
107+32	107+42	CS	Struct.	2	3	5	10		
107+32	107+42	IW	O&M	2	3	5	10		
107+34	107+45	CL	Struct.	2	8	9	11		
107+42		CC	Struct.	1	7	5	0		
107+42		IW	O&M	2	7	5	0		
107+42	107+72	CS	Struct.	2	7	3	30		
107+51		RPP	Struct.	0	12		0		
107+55		CC	Struct.	1	8	3	0		
107+56		RPP	Struct.	0	12		0		
107+56	107+66	CL	Struct.	2	3		10		
107+66	107+70	CS	Struct.	2	7	5	4		
107+67		IW	O&M	2	2		0		
107+69		IW	O&M	2	3		0		
107+70	107+85	CL	Struct.	2	3		15		
107+78		CC	Struct.	1	7	11	0		
107+78		IW	O&M	2	7	11	0		
107+78		CC	Struct.	1	3	5	0		
107+78		IW	O&M	2	3	5	0		
107+85		RPP	Struct.	0	12		0		
107+86		IW	O&M	2	4		0		
107+85	107+93	CS	Struct.	2	2	4	8		
107+88	107+93	CL	Struct.	2	9		5		
107+90		RPP	Struct.	0	12		0		
107+91		CC	Struct.	1	9	3	0		
107+93	108+02	CS	Struct.	2	2	5	9		
108+09	108+22	CS	Struct.	2	7	4	13		
108+24		RPP	Struct.	0	8	4	0		
108+26		CC	Struct.	1	11	1	0		

*Defect ratings of 4 and 5 are shaded orange and red respectively.

3rd Avenue Tunnel

Inspection Notes - Station 100+53 to 116+10

Begin Station	End Station	Code	Family	Rating	Clock From	Clock To	Length (ft.)	Percent (%)	Comment
108+28		CC	Struct.	1	7	5	0		
108+28		IW	O&M	2	7	5	0		
108+37	108+40	CS	Struct.	2	7	5	3		
108+40		IW	O&M	2	4		0		
108+39		IW	O&M	2	8		0		
108+44		IW	O&M	2	8		0		
108+51		RPP	Struct.	0	8	4	0		
108+59		RPP	Struct.	0	9	2	0		
108+61		CC	Struct.	1	8	9	0		
108+67		CC	Struct.	1	7	5	0		
108+67		ID	O&M	3	12		0		
108+72	108+77	CS	Struct.	2	7	5	5		
108+80		CC	Struct.	1	7	9	0		
108+80		IW	O&M	2	7	9	0		
108+80		CC	Struct.	1	2	5	0		
108+80		IW	O&M	2	2	5	0		
108+89		RPP	Struct.	0	3	5	0		
109+06		IW	O&M	2	8		0		
109+11		DAE	O&M	2	7	5	0		
109+11		IR	O&M	4	1		0		
109+15		CC	Struct.	1	2	5	0		
109+15		IW	O&M	2	2	5	0		
109+15		CC	Struct.	1	7	8	0		
109+15		IW	O&M	2	7	8	0		
109+26		CC	Struct.	1	11	1	0		
109+26		DAE	O&M	2	7	5	0		
109+24		DAE	O&M	2	7	10	0		
109+28		ID	O&M	3	12		0		
109+32		ID	O&M	3	12		0		

*Defect ratings of 4 and 5 are shaded orange and red respectively.

3rd Avenue Tunnel

Inspection Notes - Station 100+53 to 116+10

Begin Station	End Station	Code	Family	Rating	Clock From	Clock To	Length (ft.)	Percent (%)	Comment
109+35		DAE	O&M	2	7	5	0		
109+38		CC	Struct.	1	1	4	0		
109+41		RPP	Struct.	0	8	4	0		
109+48		DAE	O&M	2	12	4	0		
109+55		ID	O&M	3	12		0		
109+63		DAE	O&M	2	2	5	0		
109+63		IW	O&M	2	2	5	0		
109+67		CC	Struct.	1	7	1	0		
109+67		IW	O&M	2	7	1	0		
109+70		RPP	Struct.	0	8	4	0		
109+74		IW	O&M	2	2	8	0		
109+80		DAE	O&M	2	1	5	0		
109+81		DAE	O&M	2	7	9	0		
109+81		IW	O&M	2	7	9	0		
109+85		DAE	O&M	2	3	5	0		
109+85		IW	O&M	2	3	5	0		
109+85		DAE	O&M	2	7	10	0		
109+85		IW	O&M	2	7	10	0		
109+89		RPP	Struct.	0	12		0		
109+89		DAE	O&M	2	7	12	0		
109+90		RPP	Struct.	0	12		0		
109+90		IR	O&M	4	12		0		
109+90	110+00	CL	Struct.	2	9		10		
110+03		CC	Struct.	1	4	5	0		
110+08		ID	O&M	3	12		0		
110+12		RPP	Struct.	0	12		0		
110+12		IW	O&M	2	7	8	0		
110+18		RPP	Struct.	0	12		0		
110+23		RPP	Struct.	0	12		0		

*Defect ratings of 4 and 5 are shaded orange and red respectively.

3rd Avenue Tunnel

Inspection Notes - Station 100+53 to 116+10

Begin Station	End Station	Code	Family	Rating	Clock From	Clock To	Length (ft.)	Percent (%)	Comment
110+28		DAE	O&M	2	7	11	0		
110+28		IW	O&M	2	2	5	0		
110+30	110+50	RPP	Struct.	0	9		20		
110+35		RPP	Struct.	0	8	3	0		
110+35		IW	O&M	2	8		0		
110+37		DAE	O&M	2	12	5	0		
110+42		DAE	O&M	2	7	10	0		
110+42	110+47	CL	Struct.	2	3		5		
110+50		RPP	Struct.	0	7	5	0		
110+50		DAE	O&M	2	7	5	0		
110+50		IW	O&M	2	7	5	0		
110+56		RPP	Struct.	0	8	4	0		
110+60	110+67	DAE	O&M	2	7	11	7		
110+68		RPP	Struct.	0	8	4	0		
110+72		RPP	Struct.	0	11	2	0		
110+81		RPP	Struct.	0	12		0		
110+82	110+89	DAE	O&M	2	3	5	7		
110+82	110+89	DAE	O&M	2	7	10	7		
110+82	110+89	IW	O&M	2	7	10	7		
110+91		IW	O&M	2	4	5	0		
111+00		IW	O&M	2	7	8	0		
111+00		IW	O&M	2	3	4	0		
111+09	113+37	RPP	Struct.	0	12	4	228		
111+19		IW	O&M	2	7	8	0		
111+21		IW	O&M	2	4	5	0		
111+21		IW	O&M	2	7	9	0		
111+29		CC	Struct.	1	7	9	0		
111+31		IW	O&M	2	7	8	0		
111+33		IW	O&M	2	4	5	0		

*Defect ratings of 4 and 5 are shaded orange and red respectively.

3rd Avenue Tunnel

Inspection Notes - Station 100+53 to 116+10

Begin Station	End Station	Code	Family	Rating	Clock From	Clock To	Length (ft.)	Percent (%)	Comment
111+33		CC	Struct.	1	1	5	0		
111+43	111+47	CL	Struct.	2	4		4		
111+45		CC	Struct.	1	5	7	0		
111+45		IW	O&M	2	5	7	0		
111+58		IW	O&M	2	7	8	0		
111+58		IW	O&M	2	3	5	0		
111+59		CC	Struct.	1	7	8	0		
111+70		DAE	O&M	2	7	9	0		
111+70		IW	O&M	2	7	9	0		
111+75		CC	Struct.	1	7	11	0		
111+82		DAE	O&M	2	7	5	0		
111+82		IW	O&M	2	7	5	0		
111+92	111+97	DAE	O&M	2	9	5	5		
112+05		IW	O&M	2	4	5	0		
112+08		DAE	O&M	2	7	9	0		
112+08		IW	O&M	2	7	9	0		
112+10		DAE	O&M	2	4	5	0		
112+10		IW	O&M	2	4	5	0		
112+13		DAE	O&M	2	1	5	0		
112+13		DAE	O&M	2	1	5	0		
112+15		DAE	O&M	2	7	12	0		
112+32		DAE	O&M	2	7	5	0		
112+32		IW	O&M	2	7	5	0		
112+45		DAE	O&M	2	1	5	0		
112+45		IW	O&M	2	1	5	0		
112+49		DAE	O&M	2	7	12	0		
112+49		IW	O&M	2	7	12	0		
112+60		DAE	O&M	2	7	10	0		
112+60		IW	O&M	2	7	10	0		

*Defect ratings of 4 and 5 are shaded orange and red respectively.

3rd Avenue Tunnel

Inspection Notes - Station 100+53 to 116+10

Begin Station	End Station	Code	Family	Rating	Clock From	Clock To	Length (ft.)	Percent (%)	Comment
112+68		DAE	O&M	2	7	11	0		
112+68		IW	O&M	2	7	11	0		
112+73		DAE	O&M	2	3	5	0		
112+73		IW	O&M	2	3	5	0		
112+79		CC	Struct.	1	7	5	0		
112+87		DAE	O&M	2	2	5	0		
112+87		IR	O&M	4	2	5	0		
112+87		DAE	O&M	2	7	10	0		
112+87		IW	O&M	2	7	10	0		
112+99		DAE	O&M	2	7	1	0		
112+99		IW	O&M	2	7	1	0		
113+00		DAE	O&M	2	2	5	0		
113+00		IW	O&M	2	2	5	0		
113+00		ID	O&M	3	12		0		
113+03	113+07	DAE	O&M	2	7	12	4		
113+03		CC	Struct.	1	11	12	0		
113+08	113+10	DAE	O&M	2	8	5	2		
113+08	113+10	ID	O&M	3	12		2		
113+15	113+20	DAE	O&M	2	7	5	5		
113+15		ID	O&M	3	12		0		
113+28		ID	O&M	3	12		0		
113+31		DAE	O&M	2	7	11	0		
113+31		IW	O&M	2	1	5	0		
113+43		IW	O&M	2	12		0		
113+50		RPP	Struct.	0	12		0		
113+54		DAE	O&M	2	7	12	0		
113+54		IW	O&M	2	7	12	0		
113+57		DAE	O&M	2	4	5	0		
113+57		IW	O&M	2	4	5	0		

*Defect ratings of 4 and 5 are shaded orange and red respectively.

3rd Avenue Tunnel

Inspection Notes - Station 100+53 to 116+10

Begin Station	End Station	Code	Family	Rating	Clock From	Clock To	Length (ft.)	Percent (%)	Comment
113+64		DAE	O&M	2	7	9	0		
113+64		IW	O&M	2	7	9	0		
113+65		RPP	Struct.	0	7	4	0		
113+72		IR	O&M	4	7	8	0		
113+72		IR	O&M	4	2	5	0		
113+85		DAE	O&M	2	3	5	0		
113+85		IW	O&M	2	3	5	0		
113+90		DAE	O&M	2	7	5	0		
113+90		IW	O&M	2	3	5	0		
113+90		IW	O&M	2	7	8	0		
113+90		CC	Struct.	1	11	12	0		
114+00		DAE	O&M	2	2	5	0		
114+00		IW	O&M	2	2	5	0		
114+00		IW	O&M	2	7	8	0		
114+04		DAE	O&M	2	7	5	0		
114+04		IW	O&M	2	7	5	0		
114+04		ID	O&M	3	12		0		
114+21		DAE	O&M	2	4	5	0		
114+21		IW	O&M	2	4	5	0		
114+26	114+52	DAE	O&M	2	12	5	26		
114+26	114+52	IW	O&M	2	12	5	26		
114+28	114+38	DAE	O&M	2	7	12	10		
114+28	114+38	IW	O&M	2	7	12	10		
114+30		ID	O&M	3	12		0		
114+48		DAE	O&M	2	7	8	0		
114+48		IW	O&M	2	7	8	0		
114+57		DAE	O&M	2	7	12	0		
114+57		IW	O&M	2	7	12	0		
114+70		DAE	O&M	2	7	5	0		

*Defect ratings of 4 and 5 are shaded orange and red respectively.

3rd Avenue Tunnel

Inspection Notes - Station 100+53 to 116+10

Begin Station	End Station	Code	Family	Rating	Clock From	Clock To	Length (ft.)	Percent (%)	Comment
114+70		IW	O&M	2	7	5	0		
114+83		DAE	O&M	2	12	5	0		
114+83		IW	O&M	2	12	5	0		
114+90		DAE	O&M	2	12	5	0		
114+90		IW	O&M	2	12	5	0		
114+90		RPP	Struct.	0	12	2	0		
114+95		DAE	O&M	2	7	5	0		
114+95		IW	O&M	2	7	5	0		
115+00		DAE	O&M	2	4	5	0		
115+00		IW	O&M	2	4	5	0		
115+00	115+10	DAE	O&M	2	7	12	10		
115+00	115+10	IW	O&M	2	7	12	10		
115+00	115+10	DAE	O&M	2	1	5	10		
115+00	115+10	IW	O&M	2	1	5	10		
115+10		MSC	Misc.	0			0		Transition to 18' tall tunnel
115+14		RPP	Struct.	0	12	4	0		
115+24		DAE	O&M	2	7	8	0		
115+30		DAE	O&M	2	1	8	0		
115+30		DAE	O&M	2	1	5	0		
115+34		DAE	O&M	2	3	5	0		
115+36		IS	O&M	0	7	4	0		
115+40		DAE	O&M	2	4	8	0		
115+40		IW	O&M	2	4	5	0		
115+50		DAE	O&M	2	2	5	0		
115+50		CC	Struct.	1	1	5	0		
115+50		IW	O&M	2	7	8	0		
115+68		DAE	O&M	2	7	9	0		
115+73		DAE	O&M	2	7	9	0		
115+73		DAE	O&M	2	3	5	0		

*Defect ratings of 4 and 5 are shaded orange and red respectively.

3rd Avenue Tunnel

Inspection Notes - Station 100+53 to 116+10

Begin Station	End Station	Code	Family	Rating	Clock From	Clock To	Length (ft.)	Percent (%)	Comment
115+77		DAE	O&M	2	7	9	0		
115+77		DAE	O&M	2	3	5	0		
115+85		DAE	O&M	2	7	9	0		
115+85		DAE	O&M	2	3	5	0		
115+85		AMH	Const.	0			0		4' dia. RCP
115+90		DAE	O&M	2	7	9	0		
115+90		DAE	O&M	2	3	5	0		
115+95		DAE	O&M	2	7	9	0		
115+95		DAE	O&M	2	3	5	0		
116+05		DAE	O&M	2	7	9	0		
116+05		DAE	O&M	2	3	5	0		
116+10		DAE	O&M	2	7	9	0		
116+10		DAE	O&M	2	3	5	0		End of 3rd Ave. Tunnel.

*Defect ratings of 4 and 5 are shaded orange and red respectively.

I-94/2nd Street Tunnel

Inspection Notes - Station 18+54 to 65+00									
Begin Station	End Station	Code	Family	Rating	Clock From	Clock To	Length (ft.)	Percent (%)	Comment
18+54		ADP	Const.	0			0		Begin Inspection at tunnel outlet on 10/6/2020. Second bay from right. Inspectors: Joe Welna, Sam Redinger, Mike Fogarty, Gareth Becker. Corrections to the inspection stationing post inspection are shown in red in the comments.
18+54	19+10	DSF	O&M	4			56		3 of four outlet bays blocked, 8-10' of sediment
18+45		AMH	Const.	0	11		0		Manhole near outlet, no steps. Plan Station: 19+54
18+54		MWL	Misc.	0			0		2' (knee deep)
18+54	22+00	DSF	O&M	1	5	7	346		6-12" deep
18+54		MSC	Misc.	0			0		12' dia. circular pipe. Plan Station: 19+53
19+00	19+03	CL	Struct.	2	12		3		
19+10		IS	O&M	0	9		0		
19+10	19+29	CL	Struct.	2	12		19		
19+10	19+29	IS	O&M	0	12		19		Multiple points of staining
19+29		TFA	Const.	0	2		0		2' dia. RCP
19+29	19+56	CM	Struct.	3	12		27		
19+29	19+56	IS	O&M	0	12		27		
19+30		CC	Struct.	1	12	1	0		
19+30		IS	O&M	0	12	1	0		
19+32		IS	O&M	0	1		0		
19+36		IS	O&M	0	1		0		
19+48		CC	Struct.	1	12		0		
19+48		IW	O&M	2	12		0		
19+56	19+96	CL	Struct.	2	12		40		
19+68		CC	Struct.	1	7	5	0		
19+68		IW	O&M	2	7	5	0		
19+70		CC	Struct.	1	12	1	0		
19+70		IW	O&M	2	12	1	0		
19+70		CC	Struct.	1	7	9	0		
19+75		CC	Struct.	1	12	2	0		

*Defect ratings of 4 and 5 are shaded orange and red respectively.

I-94/2nd Street Tunnel

Inspection Notes - Station 18+54 to 65+00

Begin Station	End Station	Code	Family	Rating	Clock From	Clock To	Length (ft.)	Percent (%)	Comment
19+75		IW	O&M	2	12	2	0		
19+75		IW	O&M	2	12	1	0		
19+80		CC	Struct.	1	11	2	0		
19+87		CC	Struct.	1	3	5	0		
19+87	20+05	CM	Struct.	3	11	1	18		
20+00	20+07	CL	Struct.	2	1		7		
20+02		IW	O&M	2	8		0		
20+07		CC	Struct.	1	7	5	0		
20+07		IW	O&M	2	7		0		
20+07		IW	O&M	2	5		0		
20+09	20+18	CL	Struct.	2	12		9		
20+10		CC	Struct.	1	11	1	0		
20+14		IW	O&M	2	1		0		
20+18		CC	Struct.	1	8	3	0		
20+24		CC	Struct.	1	10	2	0		
20+27	20+47	CL	Struct.	2	12		20		
20+27		IW	O&M	2	8		0		
20+35		CC	Struct.	1	10	5	0		
20+40		CC	Struct.	1	10	4	0		
20+47		CC	Struct.	1	7	5	0		
20+51	20+63	CM	Struct.	3	10	2	12		
20+54		CC	Struct.	1	11	5	0		
20+54		CC	Struct.	1	8	9	0		
20+57		CC	Struct.	1	10	4	0		
20+66		CC	Struct.	1	10	1	0		
20+68	20+76	CL	Struct.	2	12		8		
20+70		CC	Struct.	1	11	1	0		
20+70	20+73	CL	Struct.	2	11		3		
20+76		CC	Struct.	1	10	2	0		

*Defect ratings of 4 and 5 are shaded orange and red respectively.

I-94/2nd Street Tunnel

Inspection Notes - Station 18+54 to 65+00

Begin Station	End Station	Code	Family	Rating	Clock From	Clock To	Length (ft.)	Percent (%)	Comment
20+81		CC	Struct.	1	7	5	0		
20+84	20+96	CL	Struct.	2	10	12	12		
20+86		CC	Struct.	1	9	2	0		
20+92		CC	Struct.	1	9	3	0		
20+96		CC	Struct.	1	9	12	0		
21+00		CC	Struct.	1	9	4	0		
21+06		CC	Struct.	1	9	3	0		
21+09	21+19	CL	Struct.	2	12		10		
21+09		CC	Struct.	1	11	1	0		
21+20		MSC	Misc.	0	0		0		Cathedral Arch: 15-6" tall Plan Station: 23+25
21+20		MWM	Misc.	0	0		0		Water mark ~10' up on Tunnel Wall
21+33		CC	Struct.	1	8	9	0		
21+33	21+36	CS	Struct.	2	9	10	3		
21+45	21+75	CL	Struct.	2	2	3	30		
21+45	21+65	CL	Struct.	2	9		20		
21+45		CC	Struct.	1	8	10	0		
21+45		CC	Struct.	1	2	4	0		
21+63		CC	Struct.	1	7	5	0		
21+63		CC	Struct.	1	7		0		
21+63		CC	Struct.	1	5		0		
21+65		CC	Struct.	1	2	5	0		
21+65		IW	O&M	2	2	5	0		
21+65	21+75	CS	Struct.	2	2	3	10		
21+69		CC	Struct.	1	7	2	0		
21+69		IW	O&M	2	7	10	0		
21+82		CC	Struct.	1	7	5	0		
21+82		IW	O&M	2	7		0		
21+82		IW	O&M	2	5		0		
21+93		CC	Struct.	1	7	5	0		

*Defect ratings of 4 and 5 are shaded orange and red respectively.

I-94/2nd Street Tunnel

Inspection Notes - Station 18+54 to 65+00

Begin Station	End Station	Code	Family	Rating	Clock From	Clock To	Length (ft.)	Percent (%)	Comment
21+93		IW	O&M	2	7		0		
21+93		IW	O&M	2	5		0		
22+04		CC	Struct.	1	3	5	0		
22+04		IW	O&M	2	3	5	0		
22+15		CC	Struct.	1	7	5	0		
22+15		IW	O&M	2	7		0		
22+15		IW	O&M	2	5		0		
22+25		CC	Struct.	1	7	10	0		
22+25		IW	O&M	2	7	10	0		
22+25		CC	Struct.	1	2	5	0		
22+35	22+36	CM	Struct.	3	10	2	1		
22+35	22+36	RPP	Struct.	0	10	2	1		
22+36		CC	Struct.	1	3	5	0		
22+36		IS	O&M	0	5		0		
22+43		CC	Struct.	1	7	10	0		
22+43		IW	O&M	2	7	10	0		
22+43		CC	Struct.	1	3	5	0		
22+44		IW	O&M	2	3		0		
22+46	22+49	CC	Struct.	1	3		3		
22+50		CC	Struct.	1	7	9	0		
22+52		CC	Struct.	1	2	3	0		
22+52		IW	O&M	2	2	3	0		
22+58	22+95	CL	Struct.	2	3		37		
22+60		IW	O&M	2	2	3	0		
22+60		CC	Struct.	1	7	10	0		
22+60		IW	O&M	2	7	10	0		
22+68		CC	Struct.	1	7	9	0		
22+75		CC	Struct.	1	7	11	0		
22+75		IW	O&M	2	7	11	0		

*Defect ratings of 4 and 5 are shaded orange and red respectively.

I-94/2nd Street Tunnel

Inspection Notes - Station 18+54 to 65+00

Begin Station	End Station	Code	Family	Rating	Clock From	Clock To	Length (ft.)	Percent (%)	Comment
22+75		CC	Struct.	1	2	5	0		
22+75	22+95	CL	Struct.	2	9		20		
22+82		CC	Struct.	1	2	5	0		
22+82		IW	O&M	2	2	5	0		
22+82		RPP	Struct.	0	2	5	0		
22+82		CC	Struct.	1	7	9	0		
22+82		IW	O&M	2	7	9	0		
22+82		RPP	Struct.	0	7	9	0		
22+93		CC	Struct.	1	2	3	0		
23+00		CC	Struct.	1	2	5	0		
23+00		CC	Struct.	1	7	9	0		
23+02	26+52	CL	Struct.	2	3		350		
23+16		CC	Struct.	1	2	5	0		
23+16		IW	O&M	2	2	5	0		
23+16		CC	Struct.	1	7	11	0		
23+16		IW	O&M	2	7	11	0		
23+30		CC	Struct.	1	2	5	0		
23+30		IW	O&M	2	2	5	0		
23+30		RPP	Struct.	0	2	5	0		
23+30		CC	Struct.	1	7	10	0		
23+30		IW	O&M	2	7	10	0		
23+30		RPP	Struct.	0	7	10	0		
23+41		CC	Struct.	1	2	5	0		
23+41		IW	O&M	2	2	5	0		
23+41		CC	Struct.	1	7	11	0		
23+41		IW	O&M	2	7	11	0		
23+43		CC	Struct.	1	3	5	0		
23+43		RPP	Struct.	0	3	5	0		
23+50		CC	Struct.	1	3	5	0		

*Defect ratings of 4 and 5 are shaded orange and red respectively.

I-94/2nd Street Tunnel

Inspection Notes - Station 18+54 to 65+00									
Begin Station	End Station	Code	Family	Rating	Clock From	Clock To	Length (ft.)	Percent (%)	Comment
23+50		IW	O&M	2	3	5	0		
23+50		CC	Struct.	1	7	9	0		
23+50		IW	O&M	2	7	9	0		
23+64		CC	Struct.	1	2	5	0		
23+64		IW	O&M	2	2	5	0		
23+64		CC	Struct.	1	7	11	0		
23+64		IW	O&M	2	7	11	0		
23+66	24+00	CL	Struct.	2	8	9	34		
23+80		CC	Struct.	1	2	5	0		
23+80		IW	O&M	2	2	5	0		
23+80		CC	Struct.	1	7	9	0		
23+80		IW	O&M	2	7	9	0		
23+80	26+75	LR	Const.	0			295		90 deg. turn to right
24+03		CC	Struct.	1	7	5	0		
24+03		IW	O&M	2	10		0		
24+20		CC	Struct.	1	7	11	0		
24+20		IW	O&M	2	7	11	0		
24+23		CC	Struct.	1	3	5	0		
24+23		IW	O&M	2	3	5	0		
24+23	25+86	CL	Struct.	2	9		163		
24+27	24+30	IW	O&M	2	8		3		
24+30		CC	Struct.	1	1	3	0		
24+30		IW	O&M	2	1	3	0		
24+40		CC	Struct.	1	2	5	0		
24+40		IW	O&M	2	2	5	0		
24+40		CC	Struct.	1	7	9	0		
24+40		IW	O&M	2	7	9	0		
24+48		CC	Struct.	1	2	5	0		
24+48		IW	O&M	2	2	5	0		

*Defect ratings of 4 and 5 are shaded orange and red respectively.

I-94/2nd Street Tunnel

Inspection Notes - Station 18+54 to 65+00

Begin Station	End Station	Code	Family	Rating	Clock From	Clock To	Length (ft.)	Percent (%)	Comment
24+48		CC	Struct.	1	7	9	0		
24+48		IW	O&M	2	7	9	0		
24+56		CC	Struct.	1	2	5	0		
24+56		IW	O&M	2	2	5	0		
24+56		CC	Struct.	1	7	9	0		
24+56		IW	O&M	2	7	9	0		
24+67		CC	Struct.	1	4	5	0		
24+77		CC	Struct.	1	2	5	0		
24+77		IW	O&M	2	2	5	0		
24+77		RPP	Struct.	0	2	5	0		
24+77		CC	Struct.	1	7	9	0		
24+77		IW	O&M	2	7	9	0		
24+77		RPP	Struct.	0	7	9	0		
24+84		CC	Struct.	1	7	9	0		
24+84		IW	O&M	2	7	9	0		
24+88		CC	Struct.	1	2	5	0		
24+88		RPP	Struct.	0	2	5	0		
24+88		IW	O&M	2	2	5	0		
24+95		CC	Struct.	1	7	10	0		
24+95		RPP	Struct.	0	7	10	0		
24+95		IW	O&M	2	7	10	0		
24+98		CC	Struct.	1	2	5	0		
25+00		CC	Struct.	1	2	5	0		
25+00		IW	O&M	2	2	5	0		
25+00		CC	Struct.	1	7	10	0		
25+00		IW	O&M	2	7	10	0		
25+06		CC	Struct.	1	4	5	0		
25+06		IW	O&M	2	4	5	0		
25+06		CC	Struct.	1	7	8	0		

*Defect ratings of 4 and 5 are shaded orange and red respectively.

I-94/2nd Street Tunnel

Inspection Notes - Station 18+54 to 65+00

Begin Station	End Station	Code	Family	Rating	Clock From	Clock To	Length (ft.)	Percent (%)	Comment
25+06		IW	O&M	2	7	8	0		
25+22		CC	Struct.	1	7	5	0		
25+22		IW	O&M	2	7	5	0		
25+37		CC	Struct.	1	7	10	0		
25+37		IW	O&M	2	7	10	0		
25+37		CC	Struct.	1	2	5	0		
25+37		IW	O&M	2	2	5	0		
25+37		ID	O&M	3	5		0		
25+50		CC	Struct.	1	4	5	0		
25+50		IW	O&M	2	4	5	0		
25+50		CS	Struct.	2	2	4	0		
25+50		IW	O&M	2	2	4	0		
25+50		CC	Struct.	1	7	12	0		
25+50		IW	O&M	2	7	12	0		
25+59		CC	Struct.	1	7	5	0		
25+59		IW	O&M	2	7	5	0		
25+80		CC	Struct.	1	7	5	0		
25+80		IW	O&M	2	7	5	0		
25+84		CC	Struct.	1	7	9	0		
25+84		CC	Struct.	1	2	5	0		
26+00		CC	Struct.	1	7	5	0		
26+00		IW	O&M	2	7	5	0		
26+16		CC	Struct.	1	7	11	0		
26+16		IW	O&M	2	7	11	0		
26+16		CC	Struct.	1	1	5	0		
26+16		IW	O&M	2	1	5	0		
26+31		CC	Struct.	1	3	5	0		
26+31		IW	O&M	2	3	5	0		
26+31		CC	Struct.	1	7	8	0		

*Defect ratings of 4 and 5 are shaded orange and red respectively.

I-94/2nd Street Tunnel

Inspection Notes - Station 18+54 to 65+00

Begin Station	End Station	Code	Family	Rating	Clock From	Clock To	Length (ft.)	Percent (%)	Comment
26+31		IW	O&M	2	7	8	0		
26+35		CC	Struct.	1	7	8	0		
26+35	26+45	IW	O&M	2	7	8	0		
26+35		CL	Struct.	2	10	8	10		
26+40		IW	O&M	2	4		0		
26+53		CC	Struct.	1	7	5	0		
26+53		IW	O&M	2	7	5	0		
26+53		RPP	Struct.	0	7	5	0		
26+75		CC	Struct.	1	12	5	0		
26+75		IW	O&M	2	12	5	0		
26+75		CC	Struct.	1	7	11	0		
26+75		IW	O&M	2	7	11	0		
26+75		TB	Const.	0	12		0		14" dia. steel pipe. Plugged approx. 45' up
26+75		IR	O&M	4	3		0		
26+78	27+75	CL	Struct.	2	3	4	97		
26+78	28+70	CL	Struct.	2	8	9	192		
26+83		CC	Struct.	1	7	4	0		
26+83		IW	O&M	2	7	4	0		
26+83		CC	Struct.	1	4	5	0		
26+83		IW	O&M	2	4	5	0		
26+83		CC	Struct.	1	7	8	0		
27+00		CC	Struct.	1	7	5	0		
27+10		CC	Struct.	1	7	8	0		
27+10		IW	O&M	2	7	8	0		
27+10		CC	Struct.	1	4	5	0		
27+10		IW	O&M	2	4	5	0		
27+19		CC	Struct.	1	8	5	0		
27+19		IW	O&M	2	8	5	0		
27+22		CC	Struct.	1	7	11	0		

*Defect ratings of 4 and 5 are shaded orange and red respectively.

I-94/2nd Street Tunnel

Inspection Notes - Station 18+54 to 65+00

Begin Station	End Station	Code	Family	Rating	Clock From	Clock To	Length (ft.)	Percent (%)	Comment
27+22		IW	O&M	2	7	11	0		
27+31		CC	Struct.	1	4	5	0		
27+31		IW	O&M	2	4	5	0		
27+31		CC	Struct.	1	7	8	0		
27+31		IW	O&M	2	7	8	0		
27+37		CC	Struct.	1	8	10	0		
27+37		CC	Struct.	1	1	5	0		
27+52		CC	Struct.	1	7	5	0		
27+52		IW	O&M	2	7	5	0		
27+60		CC	Struct.	1	7	8	0		
27+60		CC	Struct.	1	1	3	0		
27+63		CC	Struct.	1	9	11	0		
27+63		IW	O&M	2	9	11	0		
27+67		CC	Struct.	1	3	5	0		
27+67		IW	O&M	2	3	5	0		
27+67		CC	Struct.	1	7	10	0		
27+67		IW	O&M	2	7	10	0		
27+75	27+86	CM	Struct.	3	10	2	11		
27+75		CC	Struct.	1	7	9	0		
27+86	27+96	CL	Struct.	2	3		10		
27+93		CC	Struct.	1	3	5	0		
27+93		CC	Struct.	1	7	8	0		
27+96		CC	Struct.	1	9	10	0		
28+02		CC	Struct.	1	7	10	0		
28+02		CC	Struct.	1	2	5	0		
28+02		IW	O&M	2	2	5	0		
28+05	28+12	CL	Struct.	2	3		7		
28+16		CC	Struct.	1	2	5	0		
28+16		IW	O&M	2	2	5	0		

*Defect ratings of 4 and 5 are shaded orange and red respectively.

I-94/2nd Street Tunnel

Inspection Notes - Station 18+54 to 65+00

Begin Station	End Station	Code	Family	Rating	Clock From	Clock To	Length (ft.)	Percent (%)	Comment
28+27		CC	Struct.	1	2	5	0		
28+27		IW	O&M	2	2	5	0		
28+27		CC	Struct.	1	7	9	0		
28+37		CC	Struct.	1	3	5	0		
28+37		IW	O&M	2	3	5	0		
28+37		CC	Struct.	1	7	10	0		
28+37		IW	O&M	2	7	10	0		
28+50		CC	Struct.	1	2	5	0		
28+50		IW	O&M	2	2	5	0		
28+50		CC	Struct.	1	7	10	0		
28+50		IW	O&M	2	7	10	0		
28+55		CC	Struct.	1	7	9	0		
28+64		CC	Struct.	1	1	5	0		
28+64		IW	O&M	2	1	5	0		
28+64		CC	Struct.	1	7	10	0		
28+64		IW	O&M	2	7	10	0		
28+68		IW	O&M	2	4	5	0		
28+79		CC	Struct.	1	1	5	0		
28+79		ID	O&M	3	1	5	0		
28+80		CC	Struct.	1	9	11	0		
28+80		IW	O&M	2	9	11	0		
28+87		CC	Struct.	1	7	8	0		
28+87		IW	O&M	2	7	8	0		
28+90		IW	O&M	2	7	8	0		
28+95		CC	Struct.	1	1	5	0		
28+95		IW	O&M	2	1	5	0		
28+99		CC	Struct.	1	1	5	0		
28+99		IW	O&M	2	1	5	0		
28+99		CC	Struct.	1	7	11	0		

*Defect ratings of 4 and 5 are shaded orange and red respectively.

I-94/2nd Street Tunnel

Inspection Notes - Station 18+54 to 65+00

Begin Station	End Station	Code	Family	Rating	Clock From	Clock To	Length (ft.)	Percent (%)	Comment
28+99		IS	O&M	0	7	11	0		
29+05		CC	Struct.	1	4	5	0		
29+05		IW	O&M	2	4	5	0		
29+05		CC	Struct.	1	7	8	0		
29+05		IW	O&M	2	7	8	0		
29+12		CC	Struct.	1	1	5	0		
29+12		IW	O&M	2	1	5	0		
29+12		RPP	Struct.	0	1	5	0		
29+14		CC	Struct.	1	8	12	0		
29+14		IW	O&M	2	8	12	0		
29+17		CC	Struct.	1	7	10	0		
29+17		IW	O&M	2	7	10	0		
29+29		CC	Struct.	1	7	5	0		
29+29		IW	O&M	2	7	5	0		
29+46		CC	Struct.	1	7	5	0		
29+46		IW	O&M	2	7	5	0		
29+47	29+73	CL	Struct.	2	9		26		
29+53		CC	Struct.	1	1	5	0		
29+53		IW	O&M	2	1	5	0		
29+63		CC	Struct.	1	12	5	0		
29+63		IW	O&M	2	12	5	0		
29+63		CC	Struct.	1	7	11	0		
29+63		IW	O&M	2	7	11	0		
29+73		CC	Struct.	1	2	5	0		
29+73		IW	O&M	2	2	5	0		
29+73		CC	Struct.	1	7	10	0		
29+73		IW	O&M	2	7	10	0		
29+73	29+92	CL	Struct.	2	9		19		
29+82		CC	Struct.	1	3	5	0		

*Defect ratings of 4 and 5 are shaded orange and red respectively.

I-94/2nd Street Tunnel

Inspection Notes - Station 18+54 to 65+00

Begin Station	End Station	Code	Family	Rating	Clock From	Clock To	Length (ft.)	Percent (%)	Comment
29+82		IW	O&M	2	3	5	0		
29+82		CC	Struct.	1	7	8	0		
29+82		IW	O&M	2	7	8	0		
29+85		CC	Struct.	1	7	8	0		
29+89		CC	Struct.	1	3	5	0		
29+89		IW	O&M	2	3	5	0		
29+92		CC	Struct.	1	7	3	0		
29+92		IW	O&M	2	7	3	0		
29+99		CC	Struct.	1	4	5	0		
29+99		IW	O&M	2	4	5	0		
30+01		CC	Struct.	1	7	12	0		
30+01		IW	O&M	2	7	12	0		
30+01		CC	Struct.	1	2	3	0		
30+01		IW	O&M	2	2	3	0		
30+09		CC	Struct.	1	7	5	0		
30+09		IW	O&M	2	7	5	0		
30+25		CC	Struct.	1	7	5	0		
30+25		IW	O&M	2	7	5	0		
30+35	30+40	CL	Struct.	2	9		5		
30+35		IW	O&M	2	9		0		
30+35		IW	O&M	2	8		0		
30+50		CC	Struct.	1	7	5	0		
30+50		IW	O&M	2	7	5	0		
30+55	30+70	CL	Struct.	2	3		15		
30+74		CC	Struct.	1	7	5	0		
30+74		IW	O&M	2	7	5	0		
30+74		RPP	Struct.	0	7	5	0		
30+86		CC	Struct.	1	8	3	0		
30+92		CC	Struct.	1	7	5	0		

*Defect ratings of 4 and 5 are shaded orange and red respectively.

I-94/2nd Street Tunnel

Inspection Notes - Station 18+54 to 65+00

Begin Station	End Station	Code	Family	Rating	Clock From	Clock To	Length (ft.)	Percent (%)	Comment
30+92		IW	O&M	2	7	5	0		
30+98		CC	Struct.	1	3	5	0		
30+98		IW	O&M	2	3	5	0		
31+06		CC	Struct.	1	9	3	0		
31+06		IW	O&M	2	9	3	0		
31+06		IW	O&M	2	12		0		
31+12		CC	Struct.	1	12	5	0		
31+12		IW	O&M	2	12	5	0		
31+27		CC	Struct.	1	7	5	0		
31+27		IW	O&M	2	7	5	0		
31+39		CC	Struct.	1	7	5	0		
31+39		IW	O&M	2	7	5	0		
31+42	31+59	CL	Struct.	2	3		17		
31+59		CC	Struct.	1	10	5	0		
31+59		IW	O&M	2	10	5	0		
31+65		CC	Struct.	1	7	9	0		
31+65		IW	O&M	2	7	9	0		
31+68		CC	Struct.	1	7	5	0		
31+68		IW	O&M	2	7	5	0		
31+79		CC	Struct.	1	7	5	0		
31+79		IW	O&M	2	7	5	0		
31+88		CC	Struct.	1	7	5	0		
31+88		IW	O&M	2	7	5	0		
32+03		CC	Struct.	1	7	5	0		
32+03		IW	O&M	2	7	5	0		
32+11		CC	Struct.	1	7	3	0		
32+11		IW	O&M	2	7	3	0		
32+16		CC	Struct.	1	7	12	0		
32+16		IW	O&M	2	7	12	0		

*Defect ratings of 4 and 5 are shaded orange and red respectively.

I-94/2nd Street Tunnel

Inspection Notes - Station 18+54 to 65+00

Begin Station	End Station	Code	Family	Rating	Clock From	Clock To	Length (ft.)	Percent (%)	Comment
32+07	32+60	CL	Struct.	2	9		53		
32+22		CC	Struct.	1	7	5	0		
32+22		IW	O&M	2	7	5	0		
32+25	32+60	CL	Struct.	2	3		35		
32+41		CC	Struct.	1	7	5	0		
32+41		IW	O&M	2	7	5	0		
32+50		CC	Struct.	1	1	5	0		
32+50		IW	O&M	2	1	5	0		
32+55		CC	Struct.	1	7	11	0		
32+55		IW	O&M	2	7	11	0		
32+57		CC	Struct.	1	9	2	0		
32+57		IW	O&M	2	9	2	0		
32+62		CC	Struct.	1	8	5	0		
32+62		IW	O&M	2	8	5	0		
32+68	35+77	CL	Struct.	2	9		309		
32+71		CC	Struct.	1	3	5	0		
32+71		IW	O&M	2	3	5	0		
32+77		CC	Struct.	1	7	5	0		
32+77		IW	O&M	2	7	5	0		
32+78	32+86	CL	Struct.	2	3		8		
32+88		CC	Struct.	1	7	5	0		
32+88		IW	O&M	2	7	5	0		
32+90	33+20	CL	Struct.	2	3		30		
33+00		CC	Struct.	1	7	3	0		
33+03		CC	Struct.	1	7	3	0		
33+03		IW	O&M	2	7	3	0		
33+07		CC	Struct.	1	3	5	0		
33+07		IW	O&M	2	3	5	0		
33+10		CC	Struct.	1	12	5	0		

*Defect ratings of 4 and 5 are shaded orange and red respectively.

I-94/2nd Street Tunnel

Inspection Notes - Station 18+54 to 65+00

Begin Station	End Station	Code	Family	Rating	Clock From	Clock To	Length (ft.)	Percent (%)	Comment
33+10		IW	O&M	2	12	5	0		
33+10		IW	O&M	2	8		0		
33+20		CC	Struct.	1	7	5	0		
33+20		IW	O&M	2	7	5	0		
33+27		CC	Struct.	1	7	11	0		
33+27		IW	O&M	2	7	11	0		
33+27	33+53	CL	Struct.	2	3		26		
33+27	33+53	IW	O&M	2	3		26		
33+33		IW	O&M	2	8		0		
33+40		CC	Struct.	1	7	5	0		
33+40		IW	O&M	2	7	5	0		
33+40		IG	O&M	5	5		0		
33+53	34+25	CL	Struct.	2	3		72		
33+70		CC	Struct.	1	7	5	0		
33+70		IW	O&M	2	7	5	0		
33+88		CC	Struct.	1	9	5	0		
33+88		ID	O&M	3	9	5	0		
33+88		IG	O&M	5	5		0		
33+88		ID	O&M	3	11	12	0		
33+90		CC	Struct.	1	7	3	0		
33+90		IW	O&M	2	7	3	0		
33+95		CC	Struct.	1	3	5	0		
34+00		IW	O&M	2	8		0		
34+05		CC	Struct.	1	8	5	0		
34+05		IW	O&M	2	8	5	0		
34+09		CC	Struct.	1	7	5	0		
34+09		IW	O&M	2	7	5	0		
34+12		IR	O&M	4	4		0		
34+15		CC	Struct.	1	4	5	0		

*Defect ratings of 4 and 5 are shaded orange and red respectively.

I-94/2nd Street Tunnel

Inspection Notes - Station 18+54 to 65+00

Begin Station	End Station	Code	Family	Rating	Clock From	Clock To	Length (ft.)	Percent (%)	Comment
34+15		IW	O&M	2	4	5	0		
34+27		CC	Struct.	1	7	5	0		
34+27		IW	O&M	2	7	5	0		
34+40		CC	Struct.	1	8	5	0		
34+40		IW	O&M	2	7		0		
34+40		IG	O&M	5	5		0		
34+41	34+51	CL	Struct.	2	3		10		
34+50		CC	Struct.	1	7	11	0		
34+50		CC	Struct.	1	2	5	0		
34+50		IW	O&M	2	2	5	0		
34+56		CC	Struct.	1	9	3	0		
34+56		IW	O&M	2	9	3	0		
34+56		ID	O&M	3	12		0		
34+61		CC	Struct.	1	3	5	0		
34+61		IW	O&M	2	3	5	0		
34+61		IG	O&M	5	5		0		
34+61		IG	O&M	5	9		0		Significant pressure, coming from crack injection port.
34+79		CC	Struct.	1	9	3	0		
34+79	34+89	CL	Struct.	2	3		10		
34+81		IW	O&M	2	4		0		
34+89		IG	O&M	5	5		0		
34+89		CC	Struct.	1	7	5	0		
34+89		IW	O&M	2	7	5	0		
35+00		CC	Struct.	1	7	5	0		
35+00		IW	O&M	2	7	5	0		
35+06		CC	Struct.	1	12	2	0		
35+15		CC	Struct.	1	9	5	0		
35+15		IW	O&M	2	9	5	0		
35+16		IW	O&M	2	8		0		

*Defect ratings of 4 and 5 are shaded orange and red respectively.

I-94/2nd Street Tunnel

Inspection Notes - Station 18+54 to 65+00									
Begin Station	End Station	Code	Family	Rating	Clock From	Clock To	Length (ft.)	Percent (%)	Comment
35+16		RPP	Struct.	0	8		0		
35+25		CC	Struct.	1	9	4	0		
35+25		IW	O&M	2	9	4	0		
35+32		CC	Struct.	1	9	3	0		
35+45		CC	Struct.	1	7	5	0		
35+45		IW	O&M	2	7	5	0		
35+53		CC	Struct.	1	7	5	0		
35+53		IW	O&M	2	7	5	0		
35+53		IR	O&M	4	4	5	0		
35+61		CC	Struct.	1	9	5	0		
35+61		IW	O&M	2	9	5	0		
35+65		IW	O&M	2	9		0		
35+65	36+00	CL	Struct.	2	4		35		
35+80		CC	Struct.	1	7	5	0		
35+80		IW	O&M	2	7	5	0		
36+00		CC	Struct.	1	7	5	0		
36+00		IW	O&M	2	7	5	0		
36+04	36+21	CL	Struct.	2	9		17		
36+10		CC	Struct.	1	9	5	0		
36+18		IG	O&M	5	3	5	0		Occuring at multiple points in location.
36+18		CC	Struct.	1	7	5	0		
36+18		IW	O&M	2	7	5	0		
36+38		CC	Struct.	1	7	5	0		
36+38		IW	O&M	2	7	5	0		
36+50		CC	Struct.	1	9	5	0		
36+50	40+00	DSF	O&M	1	6		350		4" - 6" sediment
36+50		MWL	Misc.	0	6		0		8" water level
36+57		CC	Struct.	1	7	5	0		
36+57		IW	O&M	2	7	5	0		

*Defect ratings of 4 and 5 are shaded orange and red respectively.

I-94/2nd Street Tunnel

Inspection Notes - Station 18+54 to 65+00

Begin Station	End Station	Code	Family	Rating	Clock From	Clock To	Length (ft.)	Percent (%)	Comment
36+57		ID	O&M	3	1		0		
36+59	36+94	CL	Struct.	2	3		35		
36+59	36+97	CL	Struct.	2	9		38		
36+70		CC	Struct.	1	9	10	0		
36+70		IW	O&M	2	9	10	0		
36+70		IW	O&M	2	8		0		
36+70		CC	Struct.	1	1	1	0		
36+80		CC	Struct.	1	7	5	0		
36+80		IR	O&M	4	5		0		
36+87		CC	Struct.	1	8	3	0		
36+87		IW	O&M	2	8	3	0		
36+91		IW	O&M	2	8		0		
37+00		CC	Struct.	1	1	5	0		
37+00		IW	O&M	2	1	5	0		
37+02	37+10	CL	Struct.	2	9		8		
37+05		CC	Struct.	1	7	9	0		
37+05		IW	O&M	2	7	9	0		
37+12		IW	O&M	2	3		0		
37+15		IG	O&M	5	5		0		
37+15		IG	O&M	5	7		0		
37+15		CC	Struct.	1	7	5	0		
37+15		IW	O&M	2	7	5	0		
37+15	37+27	CL	Struct.	2	9		12		
37+31		CC	Struct.	1	7	5	0		
37+31		IW	O&M	2	7	5	0		
37+31		ID	O&M	3	11		0		
37+31		ID	O&M	3	1		0		
37+35		TB	Const.	0	12		0		14" dia. steel pipe. Plugged approx. 45' up
37+35	38+06	CL	Struct.	2	4		71		

*Defect ratings of 4 and 5 are shaded orange and red respectively.

I-94/2nd Street Tunnel

Inspection Notes - Station 18+54 to 65+00

Begin Station	End Station	Code	Family	Rating	Clock From	Clock To	Length (ft.)	Percent (%)	Comment
37+42		CC	Struct.	1	7	9	0		
37+42		IW	O&M	2	7	9	0		
37+42		CC	Struct.	1	12	3	0		
37+48		ID	O&M	3	12		0		
37+48		IG	O&M	5	4		0		
37+48		CC	Struct.	1	8	4	0		
37+48		IW	O&M	2	8	4	0		
37+59		CC	Struct.	1	7	5	0		
37+59		IW	O&M	2	7	5	0		
37+59		ID	O&M	3	12		0		
37+65		CC	Struct.	1	9	11	0		
37+65		IW	O&M	2	9	11	0		
37+68		IG	O&M	5	4		0		
37+68		ID	O&M	3	12		0		
37+68		CC	Struct.	1	9	5	0		
37+68		IW	O&M	2	9	5	0		
37+68		IG	O&M	5	5		0		
37+77		CC	Struct.	1	7	8	0		
37+77		IW	O&M	2	7	8	0		
37+77		CC	Struct.	1	3	5	0		
37+77		IW	O&M	2	3	5	0		
37+83		CC	Struct.	1	7	5	0		
37+83		IW	O&M	2	7	5	0		
37+83	37+93	CL	Struct.	2	8		10		
37+84		IG	O&M	5	4		0		
37+84		IR	O&M	4	4		0		
37+84		IW	O&M	2	3		0		
38+00		CC	Struct.	1	8	3	0		
38+00		IW	O&M	2	8	3	0		

*Defect ratings of 4 and 5 are shaded orange and red respectively.

I-94/2nd Street Tunnel

Inspection Notes - Station 18+54 to 65+00

Begin Station	End Station	Code	Family	Rating	Clock From	Clock To	Length (ft.)	Percent (%)	Comment
38+00		ID	O&M	3	11		0		
38+06		CC	Struct.	1	7	5	0		
38+06		IW	O&M	2	7	5	0		
38+06		ID	O&M	3	11		0		
38+09	39+75	CL	Struct.	2	9		166		Occurs close to cold joint.
38+15	38+35	CL	Struct.	2	3		20		
38+15		CC	Struct.	1	7	8	0		
38+15		IW	O&M	2	7	8	0		
38+28		CC	Struct.	1	9	5	0		
38+35		CC	Struct.	1	7	2	0		
38+35		IW	O&M	2	7	2	0		
38+42		CC	Struct.	1	7	5	0		
38+42		IW	O&M	2	7	5	0		
38+42		IG	O&M	5	3	5	0		
38+52		CC	Struct.	1	7	3	0		
38+52		IW	O&M	2	7	3	0		
38+60		CC	Struct.	1	4	5	0		
38+60		IW	O&M	2	4	5	0		
38+65		CC	Struct.	1	7	5	0		
38+65		IW	O&M	2	7	5	0		
38+65		ID	O&M	3	11		0		
38+69		ID	O&M	3	12		0		
38+74		CC	Struct.	1	7	12	0		
38+74		RPP	Struct.	0	7	12	0		
38+85		CC	Struct.	1	7	5	0		
38+85		IW	O&M	2	7	5	0		
38+87	38+97	CL	Struct.	2	3	4	10		
38+96		CC	Struct.	1	7	5	0		
38+96		IW	O&M	2	7	5	0		

*Defect ratings of 4 and 5 are shaded orange and red respectively.

I-94/2nd Street Tunnel

Inspection Notes - Station 18+54 to 65+00

Begin Station	End Station	Code	Family	Rating	Clock From	Clock To	Length (ft.)	Percent (%)	Comment
38+96		IG	O&M	5	3		0		
38+98		IW	O&M	2	10		0		
39+03		CC	Struct.	1	12	5	0		
39+03		IW	O&M	2	12	5	0		
39+03		ID	O&M	3	12		0		
39+03	39+12	CL	Struct.	2	3		9		
39+07		ID	O&M	3	11	12	0		
39+07		CC	Struct.	1	9	3	0		
39+07		IW	O&M	2	9	3	0		
39+16		CC	Struct.	1	7	5	0		
39+16		IW	O&M	2	7	5	0		
39+16		IR	O&M	4	12		0		
39+27		IG	O&M	5	4		0		
39+27		IR	O&M	4	3		0		
39+27		CC	Struct.	1	9	5	0		
39+27		IW	O&M	2	9	5	0		
39+29		CC	Struct.	1	7	9	0		
39+43		CC	Struct.	1	7	3	0		
39+43		IW	O&M	2	7	3	0		
39+48		CC	Struct.	1	3	5	0		
39+48		IW	O&M	2	3	5	0		
39+48		IR	O&M	4	3		0		
39+52		CC	Struct.	1	12	2	0		
39+56		CC	Struct.	1	7	5	0		
39+56		IW	O&M	2	7	5	0		
39+56		ID	O&M	3	12		0		
39+60		IW	O&M	2	1		0		
39+74		CC	Struct.	1	7	3	0		
39+74		IW	O&M	2	7	3	0		

*Defect ratings of 4 and 5 are shaded orange and red respectively.

I-94/2nd Street Tunnel

Inspection Notes - Station 18+54 to 65+00

Begin Station	End Station	Code	Family	Rating	Clock From	Clock To	Length (ft.)	Percent (%)	Comment
39+74		ID	O&M	3	1		0		
39+74	40+26	CL	Struct.	2	3	4	52		
39+85		CC	Struct.	1	7	5	0		
39+85		IW	O&M	2	3	5	0		
39+96		CC	Struct.	1	9	3	0		
39+96		IW	O&M	2	9	3	0		
39+96		ID	O&M	3	12		0		
40+00		CC	Struct.	1	7	11	0		
40+00		IW	O&M	2	7	11	0		
40+00		CC	Struct.	1	2	5	0		
40+00		IW	O&M	2	2	5	0		
40+06		IW	O&M	2	11		0		
40+06		CC	Struct.	1	3	4	0		
40+06		IW	O&M	2	3	4	0		
40+08		CC	Struct.	1	7	9	0		
40+08		IW	O&M	2	7	9	0		
40+12		CC	Struct.	1	12	5	0		
40+12		IS	O&M	0	12	5	0		
40+18		CC	Struct.	1	7	1	0		
40+32		CC	Struct.	1	7	5	0		
40+32		IW	O&M	2	7	5	0		
40+35	40+50	CL	Struct.	2	9		15		
40+40		CC	Struct.	1	9	3	0		
40+40		IW	O&M	2	9	3	0		
40+40		ID	O&M	3	11	1	0		
40+50		CC	Struct.	1	7	8	0		
40+50		CC	Struct.	1	9	5	0		
40+50		IW	O&M	2	9	5	0		
40+50	40+65	CL	Struct.	2	9		15		

*Defect ratings of 4 and 5 are shaded orange and red respectively.

I-94/2nd Street Tunnel

Inspection Notes - Station 18+54 to 65+00

Begin Station	End Station	Code	Family	Rating	Clock From	Clock To	Length (ft.)	Percent (%)	Comment
40+50	40+65	IW	O&M	2	9		15		
40+55		IW	O&M	2	8		0		
40+65		IW	O&M	2	8		0		
40+68		TBD	Const.	3	10		0		2' PVC
40+68		SAM	Struct.	4			0		Missing aggregate around tap
40+68		IW	O&M	2			0		Infiltration around tap
40+70		CC	Struct.	1	9	10	0		
40+70		IW	O&M	2	9	10	0		
40+73		CC	Struct.	1	7	5	0		
40+73		IW	O&M	2	7	5	0		
40+79		CC	Struct.	1	11	1	0		
40+79		RPP	Struct.	0	11	1	0		
40+86		CC	Struct.	1	7	4	0		
40+86		IW	O&M	2	7	4	0		
40+86	41+29	CL	Struct.	2	3		43		
40+90	41+16	CL	Struct.	2	9		26		
40+92		IR	O&M	4	9		0		
40+96		CC	Struct.	1	12	3	0		
40+96		IW	O&M	2	12	3	0		
40+99		CC	Struct.	1	3	5	0		
40+99		IW	O&M	2	3	5	0		
41+08		CC	Misc.		7	5	0		
41+08		IW	O&M	2	7	5	0		
41+17		CC	Struct.	1	8	10	0		
41+17		IW	O&M	2	8	10	0		
41+17		CC	Struct.	1	12	4	0		
41+17		IW	O&M	2	12	4	0		
41+17		ID	O&M	3	1		0		
41+31		IG	O&M	5	5		0		

*Defect ratings of 4 and 5 are shaded orange and red respectively.

I-94/2nd Street Tunnel

Inspection Notes - Station 18+54 to 65+00

Begin Station	End Station	Code	Family	Rating	Clock From	Clock To	Length (ft.)	Percent (%)	Comment
41+31		IR	O&M	4	7		0		
41+31		CC	Struct.	1	7	5	0		
41+31		IS	O&M	0	7	5	0		
41+42		CC	Struct.	1	8	3	0		
41+42		IW	O&M	2	8	3	0		
41+42		ID	O&M	3	12		0		
41+54		CC	Struct.	1	9	5	0		
41+54		IW	O&M	2	9	5	0		
41+57		IG	O&M	5	7		0		
41+57		CC	Struct.	1	7	9	0		
41+57		IW	O&M	2	7	9	0		
41+77		CC	Struct.	1	10	3	0		
41+77		IS	O&M	0	10	3	0		
41+77	41+82	CL	Struct.	2	9		5		
41+84		CC	Struct.	1	7	5	0		
41+84		IW	O&M	2	7	5	0		
41+84		IG	O&M	5	5		0		
41+84		CC	Struct.	1	4		0		
41+96		CC	Struct.	1	3	5	0		
41+96		IW	O&M	2	3	5	0		
42+06		CC	Struct.	1	7	3	0		
42+06		IW	O&M	2	7	3	0		
42+09		IR	O&M	4	5		0		
42+21	42+31	CL	Struct.	2	9		10		
42+21		CC	Struct.	1	7	4	0		
42+21		IW	O&M	2	7	4	0		
42+31		IW	O&M	2	8		0		
42+35		CC	Struct.	1	1	3	0		
42+35		IW	O&M	2	1	3	0		

*Defect ratings of 4 and 5 are shaded orange and red respectively.

I-94/2nd Street Tunnel

Inspection Notes - Station 18+54 to 65+00

Begin Station	End Station	Code	Family	Rating	Clock From	Clock To	Length (ft.)	Percent (%)	Comment
42+37	42+50	CL	Struct.	2	3		13		
42+40		CC	Struct.	1	7	5	0		
42+40		IW	O&M	2	7	5	0		
42+40		IG	O&M	5	5		0		
42+40		IR	O&M	4	12		0		
42+42		CL	Struct.	2	9		0		
42+50		IR	O&M	4	12		0		
42+50		CC	Struct.	1	10	3	0		
42+50		IW	O&M	2	10	3	0		
42+55		IW	O&M	2	4		0		
42+60		CC	Struct.	1	7	5	0		
42+60		IW	O&M	2	7	5	0		
42+61		ID	O&M	3	12		0		
42+74		IW	O&M	2	4		0		
42+75		CC	Struct.	1	7	9	0		
42+75		IW	O&M	2	7	9	0		
42+79		CC	Struct.	1	7	11	0		
42+79		IS	O&M	0	7	11	0		
42+79		IR	O&M	4	12	1	0		
42+81	42+91	CL	Struct.	2	9		10		
42+83		CC	Struct.	1	7	9	0		
42+83		IW	O&M	2	7	9	0		
42+83		CC	Struct.	1	4	5	0		
42+83		IW	O&M	2	4	5	0		
42+91		CC	Struct.	1	9	5	0		
42+91		IW	O&M	2	9	5	0		
42+98		CC	Struct.	1	7	5	0		
42+98		IW	O&M	2	7	5	0		
43+00		IG	O&M	5	5		0		

*Defect ratings of 4 and 5 are shaded orange and red respectively.

I-94/2nd Street Tunnel

Inspection Notes - Station 18+54 to 65+00

Begin Station	End Station	Code	Family	Rating	Clock From	Clock To	Length (ft.)	Percent (%)	Comment
43+02	43+18	CL	Struct.	2	9		16		
43+15		CC	Struct.	1	7	5	0		
43+15		IW	O&M	2	7	5	0		
43+15		IG	O&M	5	5		0		
43+19		IW	O&M	2	4		0		
43+27		CC	Struct.	1	10	3	0		
43+27		IW	O&M	2	10	3	0		
43+35		CC	Struct.	1	8	5	0		
43+35		IW	O&M	2	8	5	0		
43+35		IR	O&M	4	12	1	0		
43+45		CC	Struct.	1	3	5	0		
43+45		IW	O&M	2	3	5	0		
43+45		IG	O&M	5	5		0		
43+53		CC	Struct.	1	9	11	0		
43+53		IS	O&M	0	9	11	0		
43+53		CC	Struct.	1	2	3	0		
43+53		IW	O&M	2	2	3	0		
43+69		CC	Struct.	1	7	5	0		
43+69		IW	O&M	2	7	5	0		
43+69		IG	O&M	5	5		0		
43+82		IW	O&M	2	3		0		
43+87		CC	Struct.	1	7	11	0		
43+87		IW	O&M	2	7	11	0		
43+94		CC	Struct.	1	2	5	0		
43+94		IW	O&M	2	2	5	0		
43+98		IR	O&M	4	12		0		
43+99		IW	O&M	2	9		0		
44+13		CC	Struct.	1	8	5	0		
44+13		IW	O&M	2	8	5	0		

*Defect ratings of 4 and 5 are shaded orange and red respectively.

I-94/2nd Street Tunnel

Inspection Notes - Station 18+54 to 65+00

Begin Station	End Station	Code	Family	Rating	Clock From	Clock To	Length (ft.)	Percent (%)	Comment
44+13		ID	O&M	3	11		0		
44+20	44+30	CL	Struct.	2	9		10		
44+31		CC	Struct.	1	9	5	0		
44+31		IW	O&M	2	9	5	0		
44+31		IR	O&M	4	1		0		
44+49		CC	Struct.	1	7	5	0		
44+49		IW	O&M	2	7	5	0		
44+49		IR	O&M	4	5		0		
44+66		CC	Struct.	1	7	11	0		
44+66		IW	O&M	2	7	11	0		
44+66		CC	Struct.	1	1	5	0		
44+66		IW	O&M	2	1	5	0		
44+78		IW	O&M	2	4		0		
44+82		IW	O&M	2	7		0		
44+86		CC	Struct.	1	8	11	0		
44+86		IW	O&M	2	8	11	0		
44+86		CC	Struct.	1	1	5	0		
44+86		IW	O&M	2	1	5	0		
44+86		ID	O&M	3	1		0		
44+96		IW	O&M	2	8		0		
44+96		CC	Struct.	1	1	5	0		
44+96		IW	O&M	2	1	5	0		
44+96		IG	O&M	5	5		0		
45+03		CC	Struct.	1	7	11	0		
45+03		IW	O&M	2	7	11	0		
45+03		ID	O&M	3	11		0		
45+10		CC	Struct.	1	7	5	0		
45+10		IW	O&M	2	7	5	0		
45+17	45+27	CL	Struct.	2	8		10		

*Defect ratings of 4 and 5 are shaded orange and red respectively.

I-94/2nd Street Tunnel

Inspection Notes - Station 18+54 to 65+00

Begin Station	End Station	Code	Family	Rating	Clock From	Clock To	Length (ft.)	Percent (%)	Comment
45+20		CC	Struct.	1	11	2	0		
45+27		CC	Struct.	1	7	5	0		
45+27		IW	O&M	2	7	5	0		
45+33	45+53	CL	Struct.	2	3		20		
45+33	45+56	CL	Struct.	2	9		23		
45+42		CC	Struct.	1	7	2	0		
45+42		IW	O&M	2	7		0		
45+52		CC	Struct.	1	9	5	0		
45+52		IW	O&M	2	9	5	0		
45+52		IG	O&M	5	5		0		
45+56		IW	O&M	2	8		0		
45+61		CC	Struct.	1	8	4	0		
45+61		IW	O&M	2	8	4	0		
45+71	45+83	CS	Struct.	2	7	9	12		
45+82		CC	Struct.	1	9	5	0		
45+82		IW	O&M	2	9	5	0		
45+85		CC	Struct.	1	7	10	0		
45+85		IW	O&M	2	7	10	0		
45+90	45+95	CL	Struct.	2	9		5		
46+01		CC	Struct.	1	7	11	0		
46+01		IW	O&M	2	7	11	0		
46+01		CC	Struct.	1	2	5	0		
46+01		IW	O&M	2	2	5	0		
46+09		CC	Struct.	1	10	3	0		
46+09		IW	O&M	2	10	3	0		
46+12		CC	Struct.	1	7	9	0		
46+12		IW	O&M	2	7	9	0		
46+12		CC	Struct.	1	3	5	0		
46+12		IW	O&M	2	3	5	0		

*Defect ratings of 4 and 5 are shaded orange and red respectively.

I-94/2nd Street Tunnel

Inspection Notes - Station 18+54 to 65+00									
Begin Station	End Station	Code	Family	Rating	Clock From	Clock To	Length (ft.)	Percent (%)	Comment
46+12		IR	O&M	4	4		0		
46+20		CC	Struct.	1	7	5	0		
46+20		IW	O&M	2	7	5	0		
46+20		ID	O&M	3	11	1	0		
46+20		IR	O&M	4	3		0		
46+28		CC	Struct.	1	9	5	0		
46+28		IW	O&M	2	5		0		
46+40		CC	Struct.	1	7	5	0		
46+40		IW	O&M	2	7	5	0		
46+40		IG	O&M	5	9		0		
46+40	46+53	CL	Struct.	2	3		13		
46+40		ID	O&M	3	11	1	0		
46+53		CC	Struct.	1	7	3	0		
46+53		IW	O&M	2	7	3	0		
46+62		CC	Struct.	1	9	5	0		
46+62		IW	O&M	2	9	5	0		
46+71		IR	O&M	4	1		0		
46+80		CC	Struct.	1	7	5	0		
46+80		IW	O&M	2	7	5	0		
46+80		IR	O&M	4	2		0		
46+81		TB	Const.	0	0		0		14" dia. steel pipe with deposits
46+83		IW	O&M	2	4		0		
46+95		CC	Struct.	1	9	11	0		
46+95		IW	O&M	2	9	11	0		
46+95		CC	Struct.	1	1	5	0		
46+95		IW	O&M	2	1	5	0		
47+03		CC	Struct.	1	9	2	0		
47+03	47+12	CL	Struct.	2	8		9		
47+12		CC	Struct.	1	7	5	0		

*Defect ratings of 4 and 5 are shaded orange and red respectively.

I-94/2nd Street Tunnel

Inspection Notes - Station 18+54 to 65+00

Begin Station	End Station	Code	Family	Rating	Clock From	Clock To	Length (ft.)	Percent (%)	Comment
47+12		IW	O&M	2	7	5	0		
47+21		CC	Struct.	1	3	5	0		
47+21		IW	O&M	2	3	5	0		
47+33	47+43	CL	Struct.	2	8		10		
47+45		CC	Struct.	1	8	5	0		
47+45		IW	O&M	2	8	5	0		
47+57		CC	Struct.	1	9	5	0		
47+57		IW	O&M	2	9	5	0		
47+66		CC	Struct.	1	7	5	0		
47+66		IS	O&M	0	7	5	0		
47+66		ID	O&M	3	12		0		
47+84		CC	Struct.	1	7	5	0		
47+84		IW	O&M	2	7	5	0		
47+84		ID	O&M	3	3		0		
47+92		CC	Struct.	1	9	2	0		
47+92		IW	O&M	2	9	2	0		
47+92	48+13	CL	Struct.	2	9		21		
47+92	48+13	IS	O&M	0	9		21		
48+05		CC	Struct.	1	9	5	0		
48+05		IW	O&M	2	9	5	0		
48+05		IG	O&M	5	4	5	0		
48+10		CC	Struct.	1	7	5	0		
48+10		IW	O&M	2	7	5	0		
48+26		CC	Struct.	1	7	5	0		
48+26		IW	O&M	2	7	5	0		
48+36		IW	O&M	2	9		0		
48+43		CC	Struct.	1	7	5	0		
48+43		IW	O&M	2	7	5	0		
48+56	48+60	CL	Struct.	2	3		4		

*Defect ratings of 4 and 5 are shaded orange and red respectively.

I-94/2nd Street Tunnel

Inspection Notes - Station 18+54 to 65+00

Begin Station	End Station	Code	Family	Rating	Clock From	Clock To	Length (ft.)	Percent (%)	Comment
48+50		CC	Struct.	1	4	5	0		
48+50		IW	O&M	2	4	5	0		
48+58		CC	Struct.	1	7	5	0		
48+58		IW	O&M	2	7	5	0		
48+58		ID	O&M	3	11		0		
48+63	48+68	CL	Struct.	2	4		5		
48+65	48+75	CL	Struct.	2	9		10		
48+72		CC	Struct.	1	9	11	0		
48+72		IW	O&M	2	9	11	0		
48+72		ID	O&M	3	10		0		
48+76		CC	Struct.	1	8	11	0		
48+76		IW	O&M	2	8	11	0		
48+76		CC	Struct.	1	1	5	0		
48+76		IW	O&M	2	1	5	0		
48+76		IG	O&M	5			0		
48+84		CC	Struct.	1	7	5	0		
48+84		IW	O&M	2	7	5	0		
48+84		ID	O&M	3	2		0		
48+98		CC	Struct.	1	10	3	0		
48+98		IW	O&M	2	10	3	0		
48+98		ID	O&M	3	12		0		
48+98		IW	O&M	2	4		0		
49+00		CC	Struct.	1	7	10	0		
49+00		IW	O&M	2	7	10	0		
48+98	49+47	CL	Struct.	2	3		49		
48+98	49+47	IS	O&M	0	3		49		
49+12		CC	Struct.	1	7	5	0		
49+12		IW	O&M	2	7	5	0		
49+23		CC	Struct.	1	7	5	0		

*Defect ratings of 4 and 5 are shaded orange and red respectively.

I-94/2nd Street Tunnel

Inspection Notes - Station 18+54 to 65+00

Begin Station	End Station	Code	Family	Rating	Clock From	Clock To	Length (ft.)	Percent (%)	Comment
49+23		IW	O&M	2	7	5	0		
49+23		ID	O&M	3	10	12	0		
49+31		CC	Struct.	1	7	5	0		
49+31		IW	O&M	2	7	5	0		
49+31		SAM	Struct.	4	12		0		4' x 4'
49+40		CC	Struct.	1	3	5	0		
49+40		IW	O&M	2	3	5	0		
49+47		CC	Struct.	1	7	5	0		
49+47		IW	O&M	2	7	5	0		
49+47		ID	O&M	3	12	1	0		
49+49	49+55	CL	Struct.	2	9		6		
49+59		CC	Struct.	1	7	5	0		
49+59		IW	O&M	2	7	5	0		
49+56		CC	Struct.	1	4	5	0		
49+56		IW	O&M	2	4	5	0		
49+56		IR	O&M	4	5		0		
49+59	49+71	CL	Struct.	2	9		12		
49+68		CC	Struct.	1	3	5	0		
49+71		CC	Struct.	1	7	5	0		
49+71		IW	O&M	2	7	5	0		
49+71		IR	O&M	4	3	5	0		
49+85	50+00	CL	Struct.	2	9		15		
49+85	49+94	CL	Struct.	2	3		9		
49+87		CC	Struct.	1	9	4	0		
49+87		IW	O&M	2	9	4	0		
49+90		IG	O&M	5	7		0		
49+92		CC	Struct.	1	8	10	0		
49+92		IW	O&M	2	8	10	0		
49+97		CC	Struct.	1	10	3	0		

*Defect ratings of 4 and 5 are shaded orange and red respectively.

I-94/2nd Street Tunnel

Inspection Notes - Station 18+54 to 65+00

Begin Station	End Station	Code	Family	Rating	Clock From	Clock To	Length (ft.)	Percent (%)	Comment
49+97		IW	O&M	2	10	3	0		
49+97		ID	O&M	3	11	1	0		
50+00		CC	Struct.	1	7	5	0		
50+00		IW	O&M	2	7	5	0		
50+00	50+27	CL	Struct.	2	3		27		
50+17		IW	O&M	2	3	4	0		
50+23		CC	Struct.	1	7	2	0		
50+23		IW	O&M	2	7	2	0		
50+32		IW	O&M	2	11		0		
50+32		CC	Struct.	1	12	3	0		
50+42		CC	Struct.	1	7	5	0		
50+42		IW	O&M	2	7	5	0		
50+42		ID	O&M	3	12		0		
50+42	50+62	CL	Struct.	2	9		20		
50+57		CC	Struct.	1	7	5	0		
50+57		IW	O&M	2	7	5	0		
50+57		ID	O&M	3	11	1	0		
50+80		CC	Struct.	1	7	5	0		
50+80		IW	O&M	2	7	5	0		
50+80		IR	O&M	4	7		0		
50+80		ID	O&M	3	11		0		
50+93	51+00	OBZ	O&M	2	6		7		Concrete rubble in invert
51+05		CC	Struct.	1	7	5	0		
51+05		IW	O&M	2	7	5	0		
51+05		IR	O&M	4	4		0		
51+15		CC	Struct.	1	9	2	0		
51+15		IW	O&M	2	9	2	0		
51+18		CC	Struct.	1	7	9	0		
51+18		IW	O&M	2	7	9	0		

*Defect ratings of 4 and 5 are shaded orange and red respectively.

I-94/2nd Street Tunnel

Inspection Notes - Station 18+54 to 65+00

Begin Station	End Station	Code	Family	Rating	Clock From	Clock To	Length (ft.)	Percent (%)	Comment
51+26		IW	O&M	2	3		0		
51+32		CC	Struct.	1	9	5	0		
51+32		IS	O&M	0	9	5	0		
51+32	51+40	CS	Struct.	2	9	7	8		
51+40		CC	Struct.	1	7	5	0		
51+40		IW	O&M	2	7	5	0		
51+50		MGO	Misc.	0	0		0		End of Inspection for Tuesday Oct. 6 2020
51+50		MGO	Misc.	0	0		0		Begin inspection on Wednesday Oct. 7 2020. NJB2 JAW2 GWB TCK
51+50		MWL	Misc.	0	0		0		6" depth
51+53	51+76	CL	Struct.	2	9	9	23		
51+53		CC	Struct.	1	7	5	0		
51+53		IW	O&M	2	7	5	0		
51+74		CC	Struct.	1	7	5	0		
51+74		IS	O&M	0	7	5	0		
51+81		CC	Struct.	1	11	3	0		
51+90		CC	Struct.	1	7	5	0		
51+90		IW	O&M	2	7	5	0		
51+91	52+20	CL	Struct.	2	3		29		
51+95		CC	Struct.	1	7	5	0		
51+95		IW	O&M	2	7	5	0		
51+95		IW	O&M	2	8		0		
52+05		CC	Struct.	1	7	5	0		
52+05		IS	O&M	0	7	5	0		
52+20		CC	Struct.	1	7	5	0		
52+22		IW	O&M	2	5		0		
52+31	52+63	CL	Struct.	2	3		32		
52+31	52+73	CL	Struct.	2	9		42		
52+31		CC	Struct.	1	7	5	0		
52+31		IW	O&M	2	7	5	0		

*Defect ratings of 4 and 5 are shaded orange and red respectively.

I-94/2nd Street Tunnel

Inspection Notes - Station 18+54 to 65+00

Begin Station	End Station	Code	Family	Rating	Clock From	Clock To	Length (ft.)	Percent (%)	Comment
52+33		CC	Struct.	1	7	5	0		
52+33		IW	O&M	2	7	5	0		
52+31	52+63	CL	Struct.	2	3		32		
52+73		CC	Struct.	1	7	5	0		
52+80	53+06	CL	Struct.	2	3		26		
52+86		CC	Struct.	1	7	3	0		
52+86		IW	O&M	2	7	3	0		
52+88		CC	Struct.	1	3	5	0		
52+88		IW	O&M	2	3	5	0		
52+88	53+06	CL	Struct.	2	9		18		
52+91		CC	Struct.	1	9	3	0		
52+91		IW	O&M	2	9	3	0		
53+06		CC	Struct.	1	7	9	0		
53+06		IS	O&M	0	7	9	0		
53+22		MWL	Misc.	0	0		0		1' depth
53+22		CC	Struct.	1	7	5	0		
53+22		IW	O&M	2	7	5	0		
53+22		IR	O&M	4	4		0		
53+39		CC	Struct.	1	7	9	0		
53+39		IW	O&M	2	7	9	0		
53+45		CC	Struct.	1	7	9	0		
53+26		SRI	Struct.	1	5	7	0		
53+49		CC	Struct.	1	7	5	0		
53+49		IW	O&M	2	7	5	0		
53+49	53+85	CS	Struct.	2	4	1	36		
53+56		CS	Struct.	2	9	11	0		
53+56		TBD	Const.	3	10		0		2' dia. PVC
53+66		CC	Struct.	1	7	2	0		
53+66		IW	O&M	2	7	2	0		

*Defect ratings of 4 and 5 are shaded orange and red respectively.

I-94/2nd Street Tunnel

Inspection Notes - Station 18+54 to 65+00

Begin Station	End Station	Code	Family	Rating	Clock From	Clock To	Length (ft.)	Percent (%)	Comment
53+68	67+43	LU	Const.	0	0		1375		Grade steepens. Plan Stationing: 56+00 to 69+75
53+85		CC	Struct.	1	12	12	0		
53+85		IW	O&M	2	12	12	0		
53+85		ID	O&M	3	1		0		
53+85	54+00	CL	Struct.	2	2		15		
53+85	54+00	CL	Struct.	2	9		15		
54+15		CC	Struct.	1	12	12	0		
54+15		IW	O&M	2	8		0		
54+15	54+27	CL	Struct.	2	8		12		
54+20	54+27	CL	Struct.	2	2		7		
54+37		CC	Struct.	1	12	12	0		
54+37		IW	O&M	2	12	12	0		
54+60		CC	Struct.	1	9	3	0		
54+32	59+60	CL	Struct.	2	3		528		
54+64		CC	Struct.	1	12	12	0		
54+64		IG	O&M	5	5		0		
54+64		ID	O&M	3	9		0		
54+66	54+86	CL	Struct.	2	9		20		
54+87	58+79	CL	Struct.	2	9		392		
54+84		CC	Struct.	1	12	12	0		
54+84		ID	O&M	3	11		0		
54+95		CC	Struct.	1	12	4	0		
54+95		ID	O&M	3	1		0		
54+98		CC	Struct.	1	12	12	0		
54+99	58+15	LR	Const.	0	0		316		Approx. 20 deg.
55+10		CC	Struct.	1	3	6	0		
55+10		IS	O&M	0	3	6	0		
55+20		DAE	O&M	2	7	11	0		
55+20		DAE	O&M	2	1	5	0		

*Defect ratings of 4 and 5 are shaded orange and red respectively.

I-94/2nd Street Tunnel

Inspection Notes - Station 18+54 to 65+00

Begin Station	End Station	Code	Family	Rating	Clock From	Clock To	Length (ft.)	Percent (%)	Comment
55+32		IR	O&M	4	1	2	0		
55+42		DAE	O&M	2	8	5	0		
58+00		MGO	Misc.	0	0		0		Station Correction: 55+50=58+00
58+08		DAE	O&M	2	4	5	0		
58+08		CC	Struct.	1	3	5	0		
58+15		TB	Const.	0	12		0		14" dia. steel pipe, plugged approx. 50' up
58+15		CC	Struct.	1	12	12	0		
58+15		DAE	O&M	2	7	3	0		
58+28		CC	Struct.	1	7	5	0		
58+28		IS	O&M	0	7	5	0		
58+28		DAE	O&M	2	8	11	0		
58+34		CC	Struct.	1	12	12	0		
58+34		DAE	O&M	2	8	11	0		
58+41		DAE	O&M	2	4	5	0		
58+46		CC	Struct.	1	12	12	0		
58+46		DAE	O&M	2	7	11	0		
58+46		DAE	O&M	2	12	5	0		
58+62		DAE	O&M	2	7	5	0		
58+62		CC	Struct.	1	12	12	0		
58+62		IR	O&M	4	2		0		
58+63	58+73	DAE	O&M	2	4	3	10		
59+73		DAE	O&M	2	7	9	0		
58+79		DAE	O&M	2	7	10	0		
58+79		DAE	O&M	2	12	4	0		
58+79		ID	O&M	3	12	1	0		
58+88		IW	O&M	2	8		0		
58+88		IW	O&M	2	4		0		
58+97		DAE	O&M	2	9	11	0		
58+97		DAE	O&M	2	1	4	0		

*Defect ratings of 4 and 5 are shaded orange and red respectively.

I-94/2nd Street Tunnel

Inspection Notes - Station 18+54 to 65+00

Begin Station	End Station	Code	Family	Rating	Clock From	Clock To	Length (ft.)	Percent (%)	Comment
58+97		CC	Struct.	1	7	6	0		
59+00	59+11	CL	Struct.	2	8	9	11		
59+02		CC	Struct.	1	4	5	0		
59+08		CC	Struct.	1	7	5	0		
59+08		ID	O&M	3	11	2	0		
59+11		IR	O&M	4	1		0		
59+11		CC	Struct.	1	9	2	0		
59+11		DAE	O&M	2	12	2	0		
59+18		DAE	O&M	2	2	5	0		
59+18		ID	O&M	3	2		0		
59+25		DAE	O&M	2	10	1	0		
59+25		CC	Struct.	1	10	1	0		
59+41		DAE	O&M	2	8	5	0		
59+41		ID	O&M	3	1	2	0		
59+41		CC	Struct.	1	10	5	0		
59+58		CC	Struct.	1	12	12	0		
59+58		ID	O&M	3	12		0		
59+60		TBA	Const.	0	10		0		2' dia. PVC
59+60	59+90	CL	Struct.	2	9		30		
59+71		CC	Struct.	1	7	5	0		
59+72	59+78	CS	Struct.	2	10	2	6		
59+90		IS	O&M	0	4		0		
59+93		CC	Struct.	1	7	5	0		
59+93		IS	O&M	0	7	5	0		
59+93	60+12	CL	Struct.	2	3		19		
60+02		CC	Struct.	1	12	12	0		
60+02		IW	O&M	2	2		0		
60+20	60+75	CL	Struct.	2	3		55		
60+20	60+37	CL	Struct.	2	8	9	17		

*Defect ratings of 4 and 5 are shaded orange and red respectively.

I-94/2nd Street Tunnel

Inspection Notes - Station 18+54 to 65+00

Begin Station	End Station	Code	Family	Rating	Clock From	Clock To	Length (ft.)	Percent (%)	Comment
60+20		CC	Struct.	1	5	7	0		
60+28		IW	O&M	2	8		0		
60+37		DAE	O&M	2	1	5	0		
60+37		DAE	O&M	2	7	11	0		
60+38	60+75	CS	Struct.	2	7	9	37		
60+47		CC	Struct.	1	7	5	0		
60+52	60+60	CL	Struct.	2	8		8		
60+60		CC	Struct.	1	7	5	0		
60+70		CC	Struct.	1	7	9	0		
60+81	60+90	CS	Struct.	2	9	12	9		
60+90	61+21	CL	Struct.	2	3		31		
60+90	61+80	CS	Struct.	2	7	10	90		
60+96	61+00	IW	O&M	2	2		4		
61+12		CC	Struct.	1	7	8	0		
61+12		IW	O&M	2	7	8	0		
61+12		CC	Struct.	1	3	5	0		
61+12		IW	O&M	2	3	5	0		
61+21	61+41	CS	Struct.	2	1	4	20		
61+21		IW	O&M	2	8		0		
61+26		IW	O&M	2	4		0		
61+30		CC	Struct.	1	7	9	0		
61+30		IW	O&M	2	7	9	0		
61+41		CC	Struct.	1	7	5	0		
61+42		SAV	Struct.	2	4		0		6' x 12'
61+47		CC	Struct.	1	7	4	0		
61+63		CC	Struct.	1	1	5	0		
61+63		SAV	Struct.	2	0		0		1' x 8'
61+70		IW	O&M	2	4		0		
61+73		IW	O&M	2	8		0		

*Defect ratings of 4 and 5 are shaded orange and red respectively.

I-94/2nd Street Tunnel

Inspection Notes - Station 18+54 to 65+00

Begin Station	End Station	Code	Family	Rating	Clock From	Clock To	Length (ft.)	Percent (%)	Comment
61+80		FC	Struct.	2	3	5	0		
61+80		CC	Struct.	1	2	10	0		
61+80	62+42	CH2	Struct.	2	9	3	62		Cracks occur at 9 & 3 o'clock
61+93		CC	Struct.	1	7	10	0		
61+93		CC	Struct.	1	1	5	0		
61+97		IW	O&M	2	3		0		
62+14		CC	Struct.	1	7	11	0		
62+14		CC	Struct.	1	3	5	0		
62+15		CC	Struct.	1	5	8	0		
62+26		IW	O&M	2	4		0		
62+34		CC	Struct.	1	7	5	0		
62+34		IS	O&M	0	7	5	0		
62+35	62+52	CS	Struct.	2	8	10	17		
62+42	62+52	CS	Struct.	2	2	5	10		
62+52	62+62	CL	Struct.	2	8		10		
62+60		CC	Struct.	1	7	5	0		
62+62	62+73	CL	Struct.	2	10		11		
62+75		CC	Struct.	1	3	5	0		
62+75	62+84	CS	Struct.	2	8	11	9		
62+84		CC	Struct.	1	7	5	0		
62+84	63+03	CM	Struct.	3	8	3	19		
63+03	63+30	CH2	Struct.	2	9	3	27		Cracks occur at 9 & 3 o'clock
63+13		CC	Struct.	1	7	5	0		
63+40		CC	Struct.	1	1	11	0		
63+40		IW	O&M	2	1	11	0		
63+42	63+49	CL	Struct.	2	3		7		
63+45	63+53	CS	Struct.	2	7	5	8		
63+46		IW	O&M	2	9		0		
63+53		CC	Struct.	1	2	5	0		

*Defect ratings of 4 and 5 are shaded orange and red respectively.

I-94/2nd Street Tunnel

Inspection Notes - Station 18+54 to 65+00

Begin Station	End Station	Code	Family	Rating	Clock From	Clock To	Length (ft.)	Percent (%)	Comment
63+53		CC	Struct.	1	7	10	0		
63+68		TFA	Const.	0	9	10	0		4' x 6' Arch shaped lateral to drain hole No. 1 Plan Station: 63+65
63+69		CC	Struct.	1	12	5	0		
63+70	63+80	CS	Struct.	2	1	3	10		
63+74	63+80	CS	Struct.	2	7	9	6		
63+81	63+96	CS	Struct.	2	10	5	15		
63+81	63+86	CS	Struct.	2	7	5	5		
63+90	63+99	CS	Struct.	2	7	10	9		
63+95		CC	Struct.	1	7	5	0		
63+95		IW	O&M	2	7	5	0		
64+12	64+31	CH2	Struct.	2	9	3	19		Cracks occur at 9 & 3 o'clock
64+16		CC	Struct.	1	9	5	0		
64+20		CC	Struct.	1	12	12	0		
64+20		IW	O&M	2	12	12	0		
64+31		CC	Struct.	1	7	9	0		
64+37	64+45	CS	Struct.	2	10	5	8		
64+45	64+53	CM	Struct.	3	7	5	8		
64+53	64+70	CH2	Struct.	2	9	3	17		Cracks occur at 9 & 3
64+71		CC	Struct.	1	7	5	0		
64+71		IW	O&M	2	7	5	0		
64+79	64+83	CL	Struct.	2	3		4		
64+85		CC	Struct.	1	7	5	0		
64+85		IW	O&M	2	7	5	0		
64+90		CC	Struct.	1	7	5	0		
64+90		MSC	Misc.	0	0	0	0		3rd Ave. wye structure

*Defect ratings of 4 and 5 are shaded orange and red respectively.

Appendix E

Tunnel Rating Figures

Barr Footer: ArcGIS 10.7.1, 2021-01-07 14:05 File: I:\Client\BassettCreek\Work_Orders\2020\3rd Avenue Tunnel and I-94\2nd St. Tunnel Inspections\Fig E-1 Tunnel Rating O&M.mxd User: cmb3

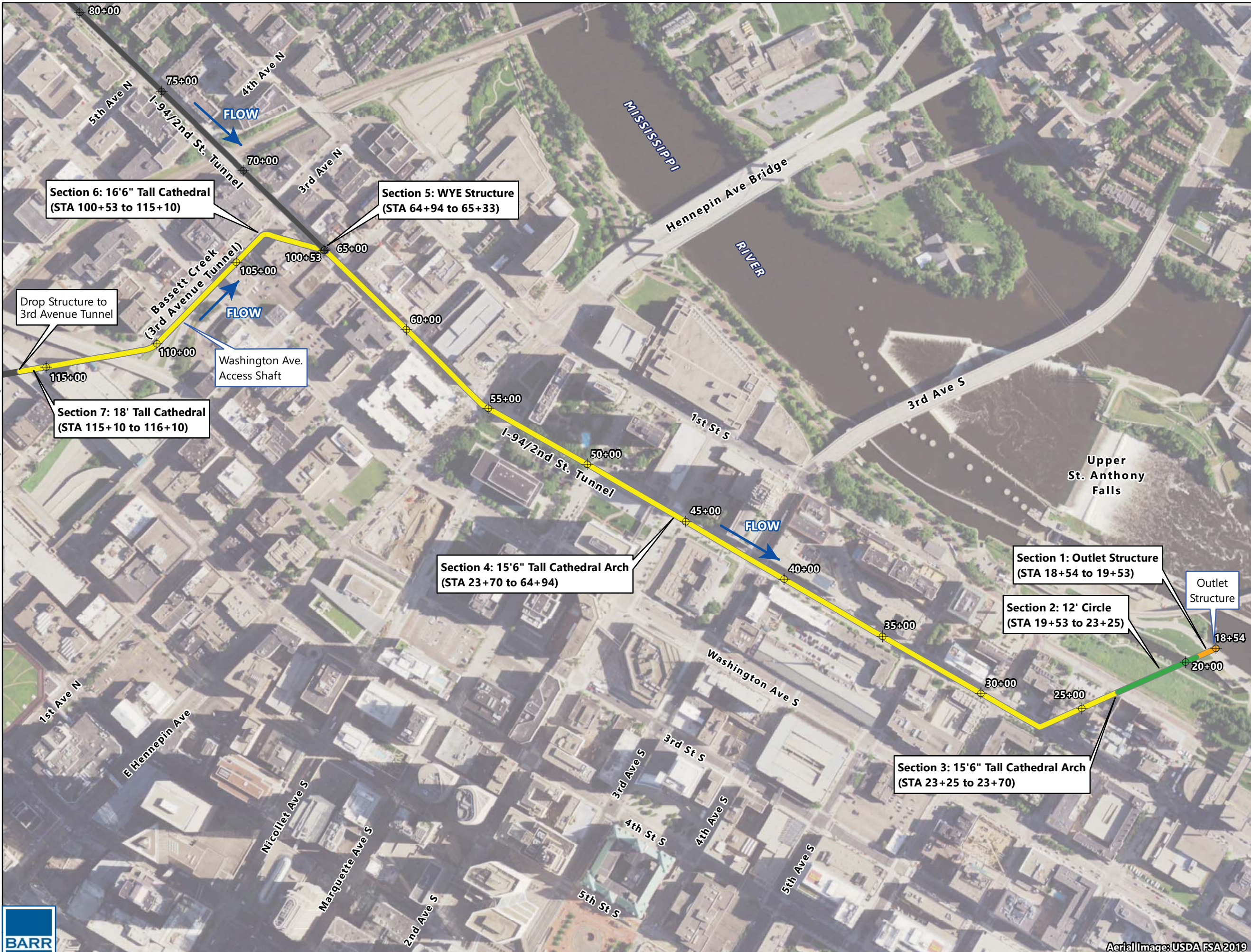

- ⊕ Stationing
- Tunnel Rating
 - Good
 - Fair
 - Poor
 - Not Inspected

Notes:
1. Grey tunnel segments were inspected under separate contracts.

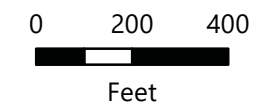

TUNNEL RATING - O&M
 2020 3rd Avenue Tunnel &
 I-94/2nd St. Tunnel Inspection
 Performed for the Bassett Creek
 Watershed Management Commission

FIGURE E-1



Aerial Image: USDA FSA 2019

Barr Footer: ArcGIS 10.7.1, 2021-01-07 14:05 File: I:\Client\BassettCreek\Work_Orders\2020\3rd Avenue Tunnel and I-94\2nd St. Tunnel Inspections\Fig E-2 Tunnel Rating Structural.mxd User: cmf3

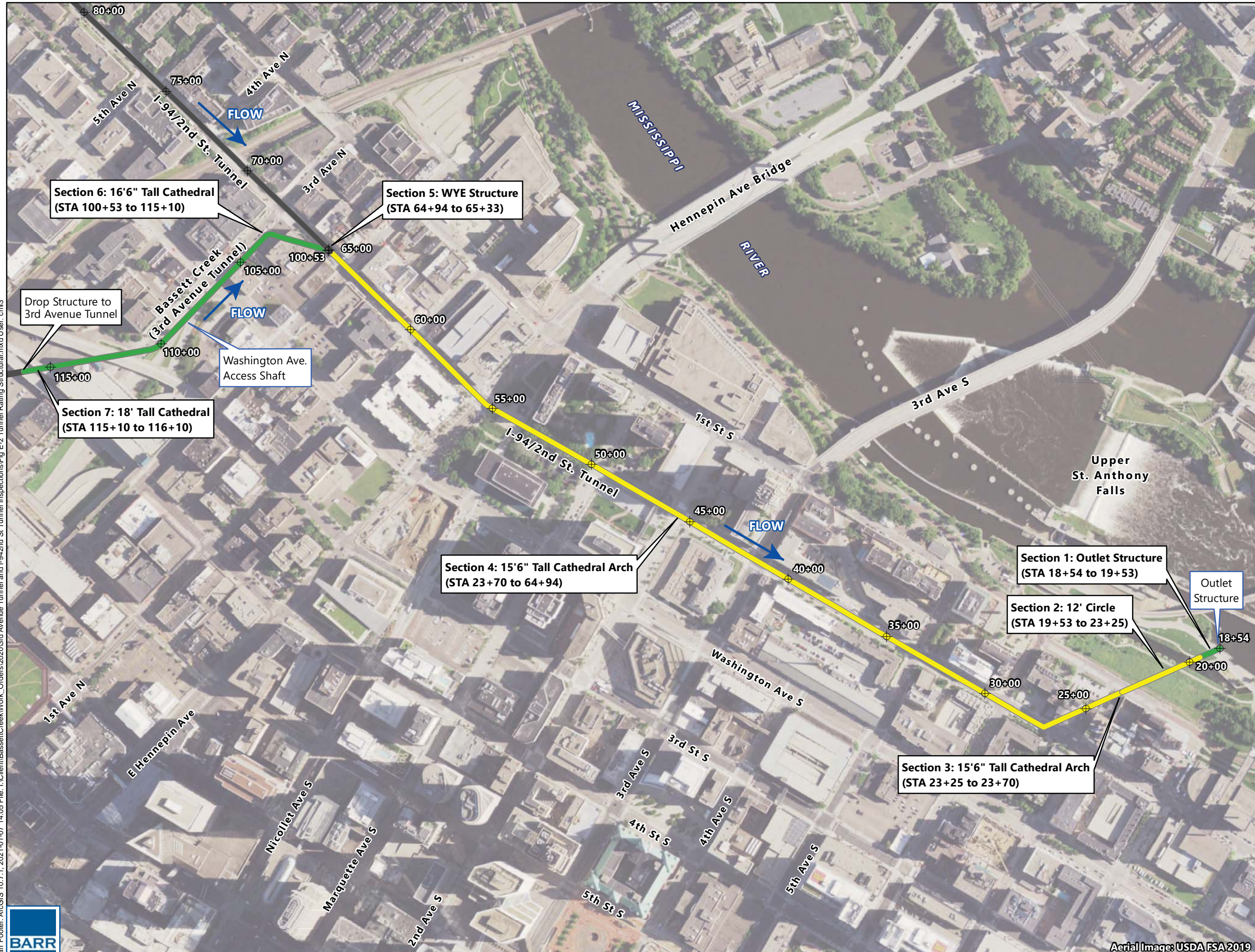

⊕ Stationing
 Tunnel Rating
█ Good
█ Fair
█ Poor
█ Not Inspected

Notes:
 1. Grey tunnel segments were inspected under separate contracts.

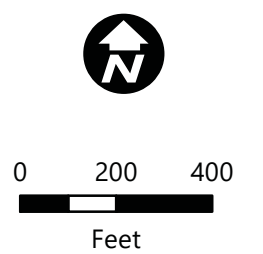

TUNNEL RATING - STRUCTURAL
 2020 3rd Avenue Tunnel &
 I-94/2nd St. Tunnel Inspection
 Performed for the Bassett Creek
 Watershed Management Commission

FIGURE E-2



Aerial Image: USDA FSA 2019