

FOUR SEASONS WATER QUALITY PROJECT

Item 5Aiii. Plan Set
BCWMC 12-15-22

GOVERNING SPECIFICATIONS
THE MINNESOTA DEPARTMENT OF TRANSPORTATION "STANDARD
CONSTRUCTION" SHALL GOVERN.

ALL TRAFFIC CONTROL DEVICES SHALL CONFORM TO THE LATEST EDITION OF THE MINNESOTA MANUAL ON UNIFORM TRAFFIC CONTROL DEVICES, INCLUDING THE LATEST FIELD MANUAL FOR TEMPORARY TRAFFIC CONTROL ZONE LAYOUTS.

CITY OF PLYMOUTH, MN

EXISTING PLAN SYMBOLS

PROPERTY LINES/RIGHT-OF-WAY	---
UTILITY EASEMENT	---
TREE LINE	~~~~~
SIGN	↑
DECIDUOUS TREE	⊗
SHRUB	⊗
CONIFEROUS TREE	⊗

EXISTING UTILITY SYMBOLS

FIBER OPTIC LINE	---	F
GAS LINE	---	G
COMMUNICATION LINE	---	C
ELECTRIC POWER LINE	---	E
WATER MAIN	---	W
SANITARY SEWER	---	S
STORM SEWER	---	SS
COMMUNICATIONS PEDESTAL	⊞	
POWER POLE	⊞	
ELECTRIC BOX	⊞	
CATCH BASIN	⊞	
STORM APRON	⊞	
STORM SEWER MANHOLE	⊞	
GATE VALVE	⊞	
HYDRANT	⊞	
SANITARY SEWER MANHOLE	⊞	

PLAN SET INDEX

Sheet List Table	
SHEET NUMBER	SHEET TITLE
1	TITLE SHEET
2	BASIN WP GRADING
3	BASIN NP AND FOREBAY GRADING
4	WETLAND GRADING AND STORM SEWER
5	BASIN WP STORM SEWER
6	BASIN NP STORM SEWER
7	SWPPP NARRATIVE 1
8	SWPPP NARRATIVE 2
9	SWPPP NARRATIVE 3
10	MISCELLANEOUS DETAILS
11	EROSION CONTROL PLAN BASIN WP
12	EROSION CONTROL PLAN BASIN NP
13	EROSION CONTROL PLAN WETLAND

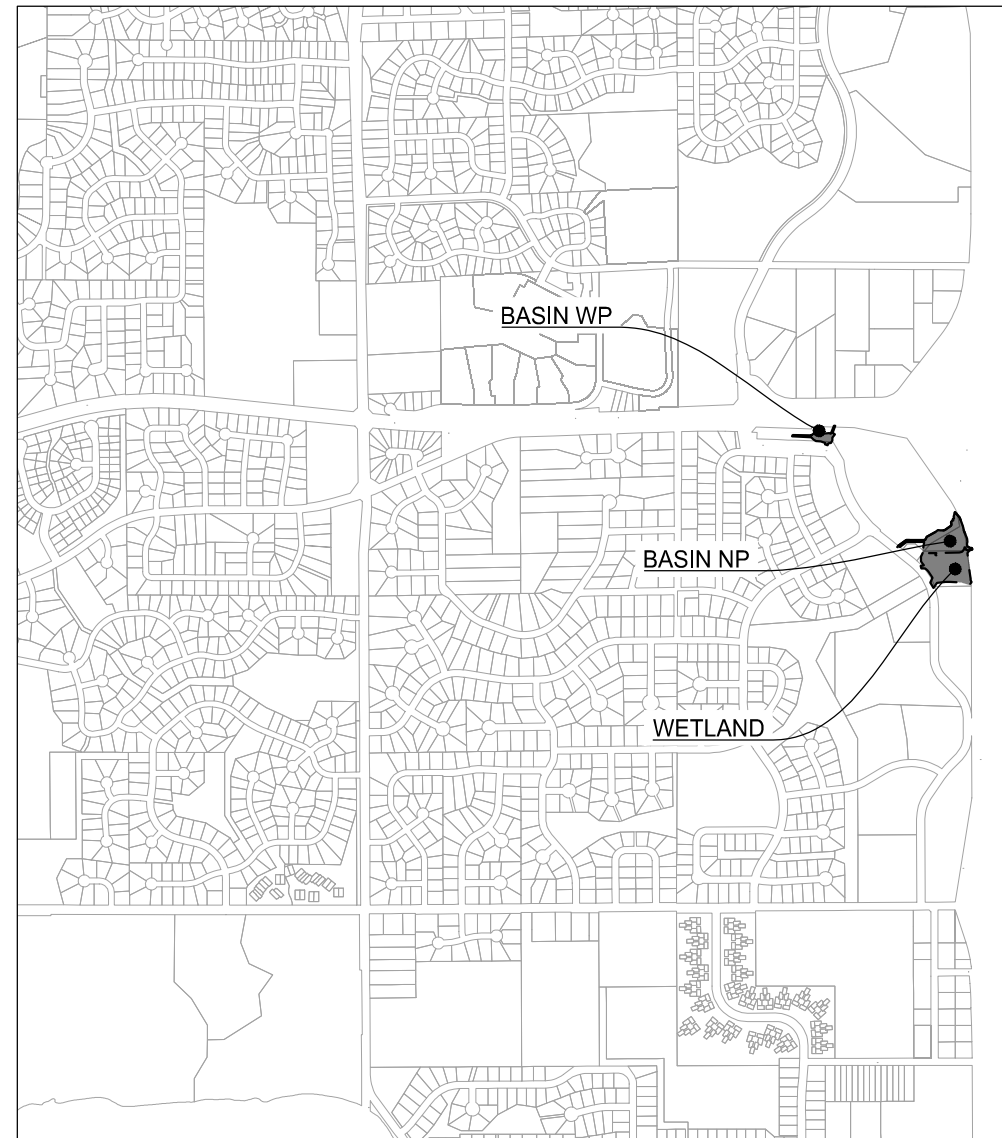

PROJECT LOCATION MAP

EXCAVATION NOTICE SYSTEM

A CALL TO GOPHER STATE ONE (651-454-0002) IS REQUIRED A MINIMUM OF 48 HOURS PRIOR TO PERFORMING ANY EXCAVATION.

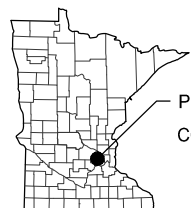

PROJECT LOCATION
COUNTY: HENNEPIN

UTILITY INFORMATION

THE SUBSURFACE UTILITY INFORMATION IN THIS PLAN IS UTILITY QUALITY LEVEL D. THIS UTILITY QUALITY LEVEL WAS DETERMINED ACCORDING TO THE GUIDELINES OF CI/ASCE 38-02, ENTITLED "STANDARD GUIDELINES FOR THE COLLECTION AND DEPICTION OF EXISTING SUBSURFACE UTILITY DATA."

GOPHER ONE CALL TICKET NUMBER: N/A

UTILITY COORDINATION MEETING HELD ON: N/A

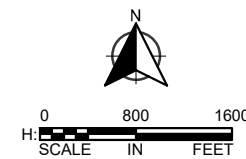

PLAN REVISIONS		
DATE	SHEET NO.	APPROVED BY

CITY OF PLYMOUTH
3400 PLYMOUTH BLVD
PLYMOUTH MN 55447
(763) 509-5000



ALL APPLICABLE FEDERAL, STATE, AND LOCAL LAWS AND ORDINANCES WILL BE COMPLIED WITH IN THE CONSTRUCTION OF THIS PROJECT.



I HEREBY CERTIFY THAT THIS PLAN WAS PREPARED BY ME OR UNDER MY DIRECT SUPERVISION, AND THAT I AM A DULY LICENSED PROFESSIONAL ENGINEER UNDER THE LAWS OF THE STATE OF MINNESOTA.

JACOB H. NEWHALL

DATE: 12-05-2022

LICENSE NUMBER: 49170

WSB PROJ. NO. 021322-000
CITY PROJ. NO. WR220004

SHEET
1
OF
13

K:\021322-000\Cad\Plan\021322-000-C-SITE-PLAN.dwg 12/5/2022 2:58:16 PM

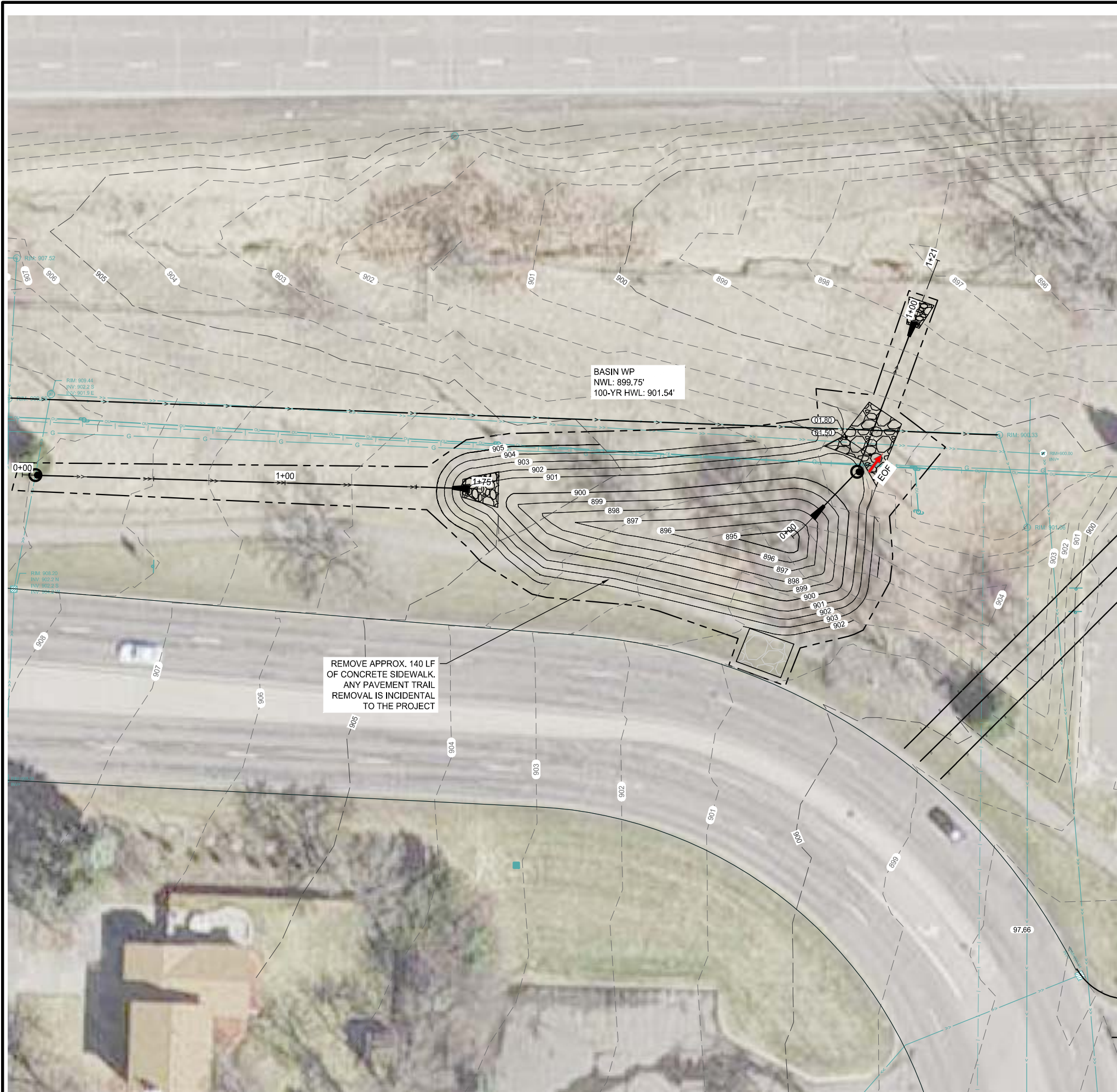

REMOVE APPROX. 140 LF OF CONCRETE SIDEWALK. ANY PAVEMENT TRAIL REMOVAL IS INCIDENTAL TO THE PROJECT

BASIN WP
NWL: 899.75'
100-YR HWL: 901.54'

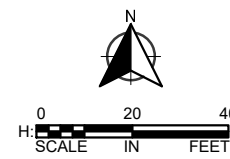

LEGEND

- INLET PROTECTION
- CLASS III RIP RAP
- SILT FENCE
- APPROX. CONSTRUCTION LIMITS
- WOOD FIBER BIOROLL
- SEED MIX 25-131 (220 LBS/ACRE) WITH FERTILIZER TYPE 3 (350 LBS/ACRE) & TYPE 3 MULCH (2 TONS/ACRE) WITH DISC ANCHOR.
- SEED MIX 33-261 (35 LBS/ACRE) WITH FERTILIZER TYPE 4 (150LBS/ACRE) & CATEGORY 3N EROSION CONTROL BLANKET. TEMPORARY STABILIZATION: TYPE 3 MULCH WITH DISC ANCHOR
- TYPE 2 WETLAND: 6 INCHES OF WATER SEED MIX 34-271
- TYPE 3 WETLAND: 1-2 FEET OF WATER SEED MIX 34-181
- TYPE 4 WETLAND: ABOVE NWL SEED MIX 34-262
- 1019 EXISTING CONTOUR (MAJOR)
- 1019 EXISTING CONTOUR (MINOR)
- 1019 PROPOSED CONTOUR (MAJOR)
- 1019 PROPOSED CONTOUR (MINOR)
- EXISTING STORM SEWER PIPE
- EXISTING STORM STRUCTURE

GENERAL CONSTRUCTION NOTES

1. RESTORE ALL POND EDGES AND WOODED AREAS WITH TYPE 33-261 SEED (35 LBS/AC) AND FERTILIZER TYPE 4 (150 LBS/ACRE). CATEGORY 3N EROSION CONTROL BLANKET SHALL BE INSTALLED ALONG POND EDGES, BUFFERS, AND NON-MOWABLE SLOPES AS DIRECTED BY THE ENGINEER IN THE FIELD. TEMPORARY STABILIZATION: TYPE 3 MULCH WITH DISC ANCHOR.
2. IN THE EVENT THAT RESTORATION CANNOT BE IMPLEMENTED WITHIN 14 DAYS AFTER CONSTRUCTION ACTIVITY IN THE DISTURBED AREA HAS CEASED, TEMPORARY EROSION STABILIZATION BMPs MUST BE SCHEDULED TO OCCUR WITHIN THAT 14 DAY TIME FRAME.
3. CONTRACTOR RESPONSIBLE FOR THE DAMAGE TO STREETS, CONCRETE CURB AND GUTTER, SIDEWALKS, AND DRIVEWAYS.
4. DAILY STREET SWEEPING REQUIRED DURING HAULING OPERATIONS (INCIDENTAL TO MOBILIZATION).
5. DEWATERING/DEICING TO TAKE PLACE PRIOR TO EXCAVATION. ICE IS TO BE STOCKPILED ON SITE AND PUT BACK IN POND FOLLOWING THE EXCAVATION. DEWATERING PLANS MUST BE DEVELOPED IN ACCORDANCE WITH SWPPP GUIDELINES AND APPROVED BY THE ENGINEER PRIOR TO COMMENCING.
6. CONTRACTOR SHALL PERFORM ALL DEWATERING AND EXCAVATION ONSITE AND OFF OF ROADWAY, AND LOAD AND HAUL OUT USING ACCESS ROUTE.
7. CONTRACTOR TO GRADE AROUND EXISTING STORM SEWER STRUCTURES AS DIRECTED BY THE ENGINEER.
8. CONTRACTOR TO COORDINATE ACCESS LIMITS WITH THE ENGINEER IN THE FIELD.
9. CONTRACTOR SHALL REMOVE TREES AS NEEDED TO ACCESS SITE.



SCALE: AS SHOWN
DESIGN BY: SML
PLAN BY: LGR
CHECK BY: JHN

REVISIONS

NO.	DATE	DESCRIPTION

I HEREBY CERTIFY THAT THIS PLAN, SPECIFICATION, OR REPORT WAS PREPARED BY ME OR UNDER MY DIRECT SUPERVISION AND THAT I AM A DULY LICENSED PROFESSIONAL ENGINEER UNDER THE LAWS OF THE STATE OF MINNESOTA.

JACOB NEWHALL
DATE: 12-05-2022 LIC. NO.: 49170

BASIN WP GRADING

**FOUR SEASONS WATER QUALITY PROJECT
CITY OF PLYMOUTH, MN**

CLIENT PROJECT NO. WR220004

WSB PROJECT NO. 021322-000

SHEET 2 OF 13

K:\021322-000\Cad\Plan\021322-000-C-SITE-PLAN.dwg 12/05/2022 3:02:28 PM

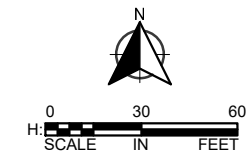
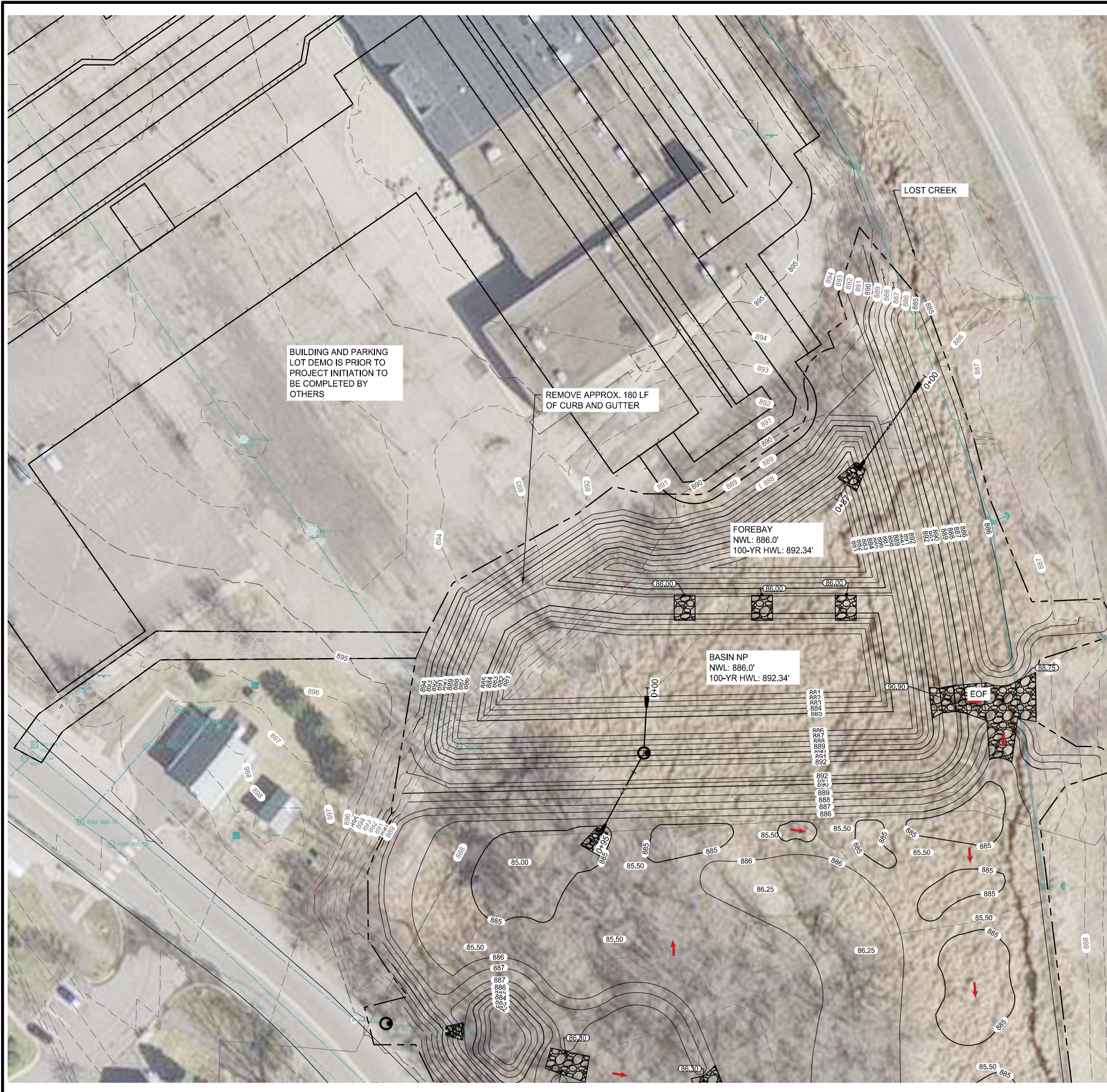

LOCATION



LEGEND

- INLET PROTECTION
- CLASS III RIP RAP
- SILT FENCE
- APPROX. CONSTRUCTION LIMITS
- WOOD FIBER BIOROLL
- SEED MIX 25-131 (220 LBS/ACRE) WITH FERTILIZER TYPE 3 (350 LBS/ACRE) & TYPE 3 MULCH (2 TONS/ACRE) WITH DISC ANCHOR.
- SEED MIX 33-261 (35 LBS/ACRE) WITH FERTILIZER TYPE 4 (150 LBS/ACRE) & CATEGORY 3N EROSION CONTROL BLANKET. TEMPORARY STABILIZATION: TYPE 3 MULCH WITH DISC ANCHOR
- TYPE 2 WETLAND: 6 INCHES OF WATER SEED MIX 34-271
- TYPE 3 WETLAND: 1-2 FEET OF WATER SEED MIX 34-181
- TYPE 4 WETLAND: ABOVE NWL SEED MIX 34-262
- EXISTING CONTOUR (MAJOR)
- EXISTING CONTOUR (MINOR)
- PROPOSED CONTOUR (MAJOR)
- PROPOSED CONTOUR (MINOR)
- EXISTING STORM SEWER PIPE
- EXISTING STORM STRUCTURE

GENERAL CONSTRUCTION NOTES

1. RESTORE ALL POND EDGES AND WOODED AREAS WITH TYPE 33-261 SEED (35 LBS/AC) AND FERTILIZER TYPE 4 (150 LBS/ACRE). CATEGORY 3N EROSION CONTROL BLANKET SHALL BE INSTALLED ALONG POND EDGES, BUFFERS, AND NON-MOWABLE SLOPES AS DIRECTED BY THE ENGINEER IN THE FIELD. TEMPORARY STABILIZATION: TYPE 3 MULCH WITH DISC ANCHOR.
2. IN THE EVENT THAT RESTORATION CANNOT BE IMPLEMENTED WITHIN 14 DAYS AFTER CONSTRUCTION ACTIVITY IN THE DISTURBED AREA HAS CEASED, TEMPORARY EROSION STABILIZATION BMPs MUST BE SCHEDULED TO OCCUR WITHIN THAT 14 DAY TIME FRAME.
3. CONTRACTOR RESPONSIBLE FOR THE DAMAGE TO STREETS, CONCRETE CURB AND GUTTER, SIDEWALKS, AND DRIVEWAYS.
4. DAILY STREET SWEEPING REQUIRED DURING HAULING OPERATIONS (INCIDENTAL TO MOBILIZATION).
5. DEWATERING/DEICING TO TAKE PLACE PRIOR TO EXCAVATION. ICE IS TO BE STOCKPILED ON SITE AND PUT BACK IN POND FOLLOWING THE EXCAVATION. DEWATERING PLANS MUST BE DEVELOPED IN ACCORDANCE WITH SWPPP GUIDELINES AND APPROVED BY THE ENGINEER PRIOR TO COMMENCING.
6. CONTRACTOR SHALL PERFORM ALL DEWATERING AND EXCAVATION ONSITE AND OFF OF ROADWAY, AND LOAD AND HAUL OUT USING ACCESS ROUTE.
7. CONTRACTOR TO GRADE AROUND EXISTING STORM SEWER STRUCTURES AS DIRECTED BY THE ENGINEER.
8. CONTRACTOR TO COORDINATE ACCESS LIMITS WITH THE ENGINEER IN THE FIELD.
9. CONTRACTOR SHALL REMOVE TREES AS NEEDED TO ACCESS SITE.



SCALE: AS SHOWN
 PLAN BY: LGR
 DESIGN BY: SML
 CHECK BY: JHN

REVISIONS

NO.	DATE	DESCRIPTION

I HEREBY CERTIFY THAT THIS PLAN, SPECIFICATION, OR REPORT WAS PREPARED BY ME OR UNDER MY DIRECT SUPERVISION AND THAT I AM A DULY LICENSED PROFESSIONAL ENGINEER UNDER THE LAWS OF THE STATE OF MINNESOTA.

JACOB NEWMHALL
 DATE: 12-05-2022 LIC. NO.: 49170

BASIN NP AND FOREBAY GRADING

**FOUR SEASONS WATER QUALITY PROJECT
 CITY OF PLYMOUTH, MN**

CLIENT PROJECT NO. WR220004

WSB PROJECT NO. 021322-000

SHEET 3 OF 13

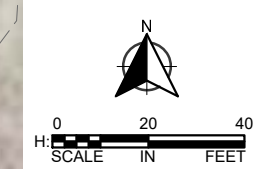
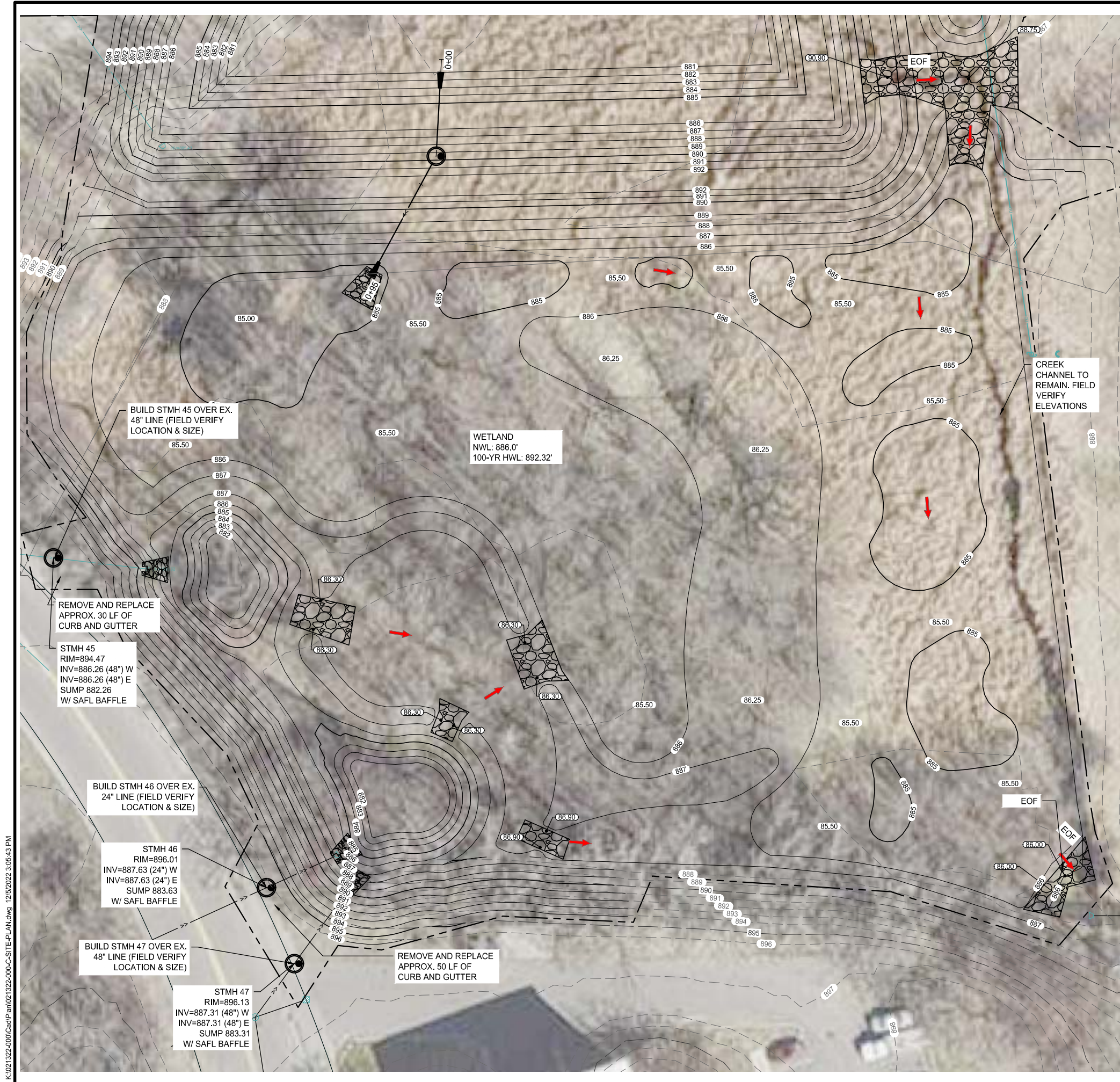

LEGEND

- INLET PROTECTION
- CLASS III RIP RAP
- SILT FENCE
- APPROX. CONSTRUCTION LIMITS
- WOOD FIBER BIOROLL
- SEED MIX 25-131 (220 LBS/ACRE) WITH FERTILIZER TYPE 3 (350 LBS/ACRE) & TYPE 3 MULCH (2 TONS/ACRE) WITH DISC ANCHOR.
- SEED MIX 33-261 (35 LBS/ACRE) WITH FERTILIZER TYPE 4 (150LBS/ACRE) & CATEGORY 3N EROSION CONTROL BLANKET. TEMPORARY STABILIZATION: TYPE 3 MULCH WITH DISC ANCHOR
- TYPE 2 WETLAND: 6 INCHES OF WATER SEED MIX 34-271
- TYPE 3 WETLAND: 1-2 FEET OF WATER SEED MIX 34-181
- TYPE 4 WETLAND: ABOVE NWL SEED MIX 34-262
- 1019- EXISTING CONTOUR (MAJOR)
- 1019- EXISTING CONTOUR (MINOR)
- 1019- PROPOSED CONTOUR (MAJOR)
- 1019- PROPOSED CONTOUR (MINOR)
- EXISTING STORM SEWER PIPE
- EXISTING STORM STRUCTURE

- GENERAL CONSTRUCTION NOTES**
1. RESTORE ALL POND EDGES AND WOODED AREAS WITH TYPE 33-261 SEED (35 LBS/AC) AND FERTILIZER TYPE 4 (150 LBS/ACRE). CATEGORY 3N EROSION CONTROL BLANKET SHALL BE INSTALLED ALONG POND EDGES, BUFFERS, AND NON-MOWABLE SLOPES AS DIRECTED BY THE ENGINEER IN THE FIELD. TEMPORARY STABILIZATION: TYPE 3 MULCH WITH DISC ANCHOR.
 2. IN THE EVENT THAT RESTORATION CANNOT BE IMPLEMENTED WITHIN 14 DAYS AFTER CONSTRUCTION ACTIVITY IN THE DISTURBED AREA HAS CEASED, TEMPORARY EROSION STABILIZATION BMPs MUST BE SCHEDULED TO OCCUR WITHIN THAT 14 DAY TIME FRAME.
 3. CONTRACTOR RESPONSIBLE FOR THE DAMAGE TO STREETS, CONCRETE CURB AND GUTTER, SIDEWALKS, AND DRIVEWAYS.
 4. DAILY STREET SWEEPING REQUIRED DURING HAULING OPERATIONS (INCIDENTAL TO MOBILIZATION).
 5. DEWATERING/DEICING TO TAKE PLACE PRIOR TO EXCAVATION. ICE IS TO BE STOCKPILED ON SITE AND PUT BACK IN POND FOLLOWING THE EXCAVATION. DEWATERING PLANS MUST BE DEVELOPED IN ACCORDANCE WITH SWPPP GUIDELINES.
 6. CONTRACTOR SHALL PERFORM ALL DEWATERING AND EXCAVATION ONSITE AND OFF OF ROADWAY, AND LOAD AND HAUL OUT USING ACCESS ROUTE.
 7. CONTRACTOR TO GRADE AROUND EXISTING STORM SEWER STRUCTURES AS DIRECTED BY THE ENGINEER.
 8. CONTRACTOR TO COORDINATE ACCESS LIMITS WITH THE ENGINEER IN THE FIELD.
 9. CONTRACTOR SHALL REMOVE TREES AS NEEDED TO ACCESS SITE.

wsb

SCALE: AS SHOWN DESIGN BY: SML
 PLAN BY: LGR CHECK BY: JHN

REVISIONS

NO.	DATE	DESCRIPTION

I HEREBY CERTIFY THAT THIS PLAN, SPECIFICATION, OR REPORT WAS PREPARED BY ME OR UNDER MY DIRECT SUPERVISION AND THAT I AM A DULY LICENSED PROFESSIONAL ENGINEER UNDER THE LAWS OF THE STATE OF MINNESOTA.

JACOB NEWHALL LIC. NO.: 49170
 DATE: 12-05-2022

WETLAND GRADING AND STORM SEWER

**FOUR SEASONS WATER QUALITY PROJECT
CITY OF PLYMOUTH, MN**

K:\021322-000\Cadd\Plan\021322-000-C-SITE-PLAN.dwg 12/05/2022 3:05:43 PM

K:\021322-000\Cad\Proposed\021322-000-CP-JTL-BASE.dwg 12/5/2022 3:13:15 PM

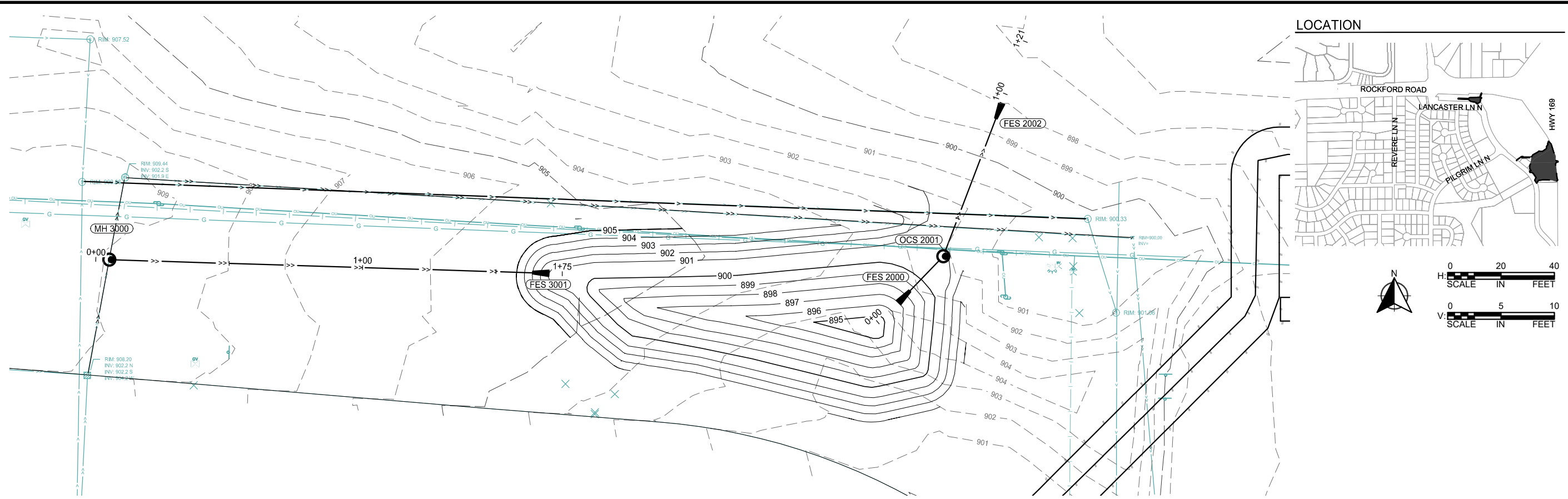

LOCATION

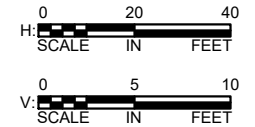

BASIN WP

SCALE: AS SHOWN
 DESIGN BY: SML
 PLAN BY: LGR
 CHECK BY: JHN

REVISIONS	
NO.	DESCRIPTION

I HEREBY CERTIFY THAT THIS PLAN, SPECIFICATION, OR REPORT WAS PREPARED BY ME OR UNDER MY DIRECT SUPERVISION AND THAT I AM A DULY LICENSED PROFESSIONAL ENGINEER UNDER THE LAWS OF THE STATE OF MINNESOTA.

JACOB NEWHALL
 DATE: 12-05-2022 LIC. NO.: 49170

BASIN WP
 STORM SEWER

FOUR SEASONS WATER QUALITY PROJECT
 CITY OF PLYMOUTH, MN

CLIENT PROJECT NO.
 WR220004

WSB PROJECT NO.
 021322-000

SHEET
 5 OF 13

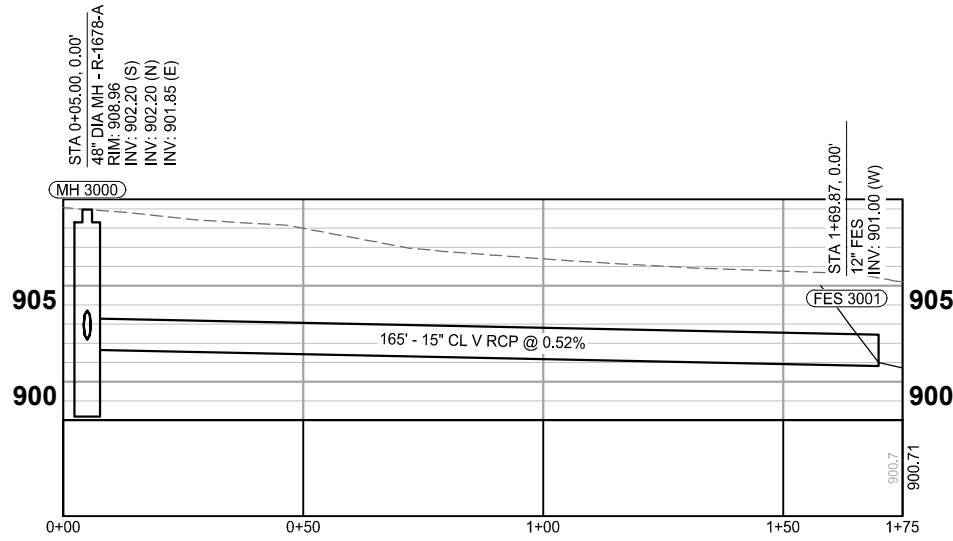
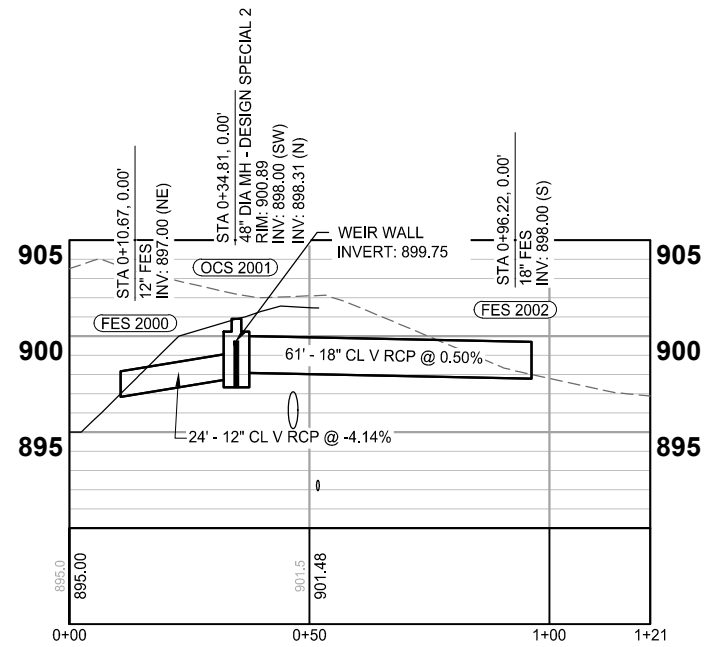

K:\021322-000\Cad\Proposed\021322-000-CP-JTL-BASE.dwg 12/5/2022 3:14:20 PM

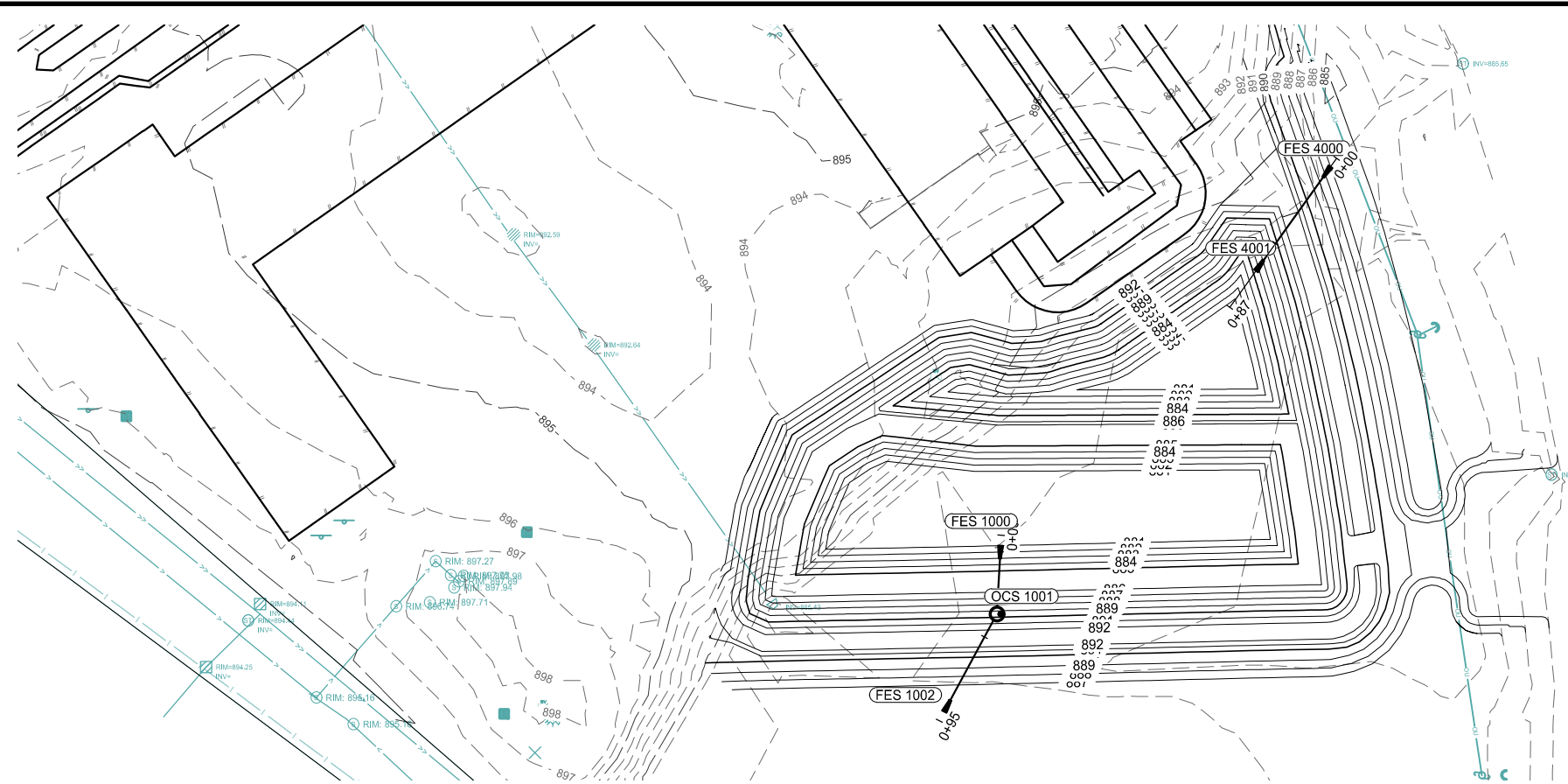

BASIN NP

LOCATION

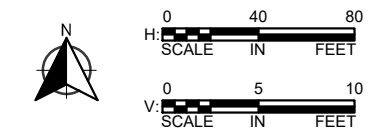

SCALE: AS SHOWN
 PLAN BY: LGR
 DESIGN BY: SML
 CHECK BY: JHN

REVISIONS	
NO.	DESCRIPTION

I HEREBY CERTIFY THAT THIS PLAN, SPECIFICATION, OR REPORT WAS PREPARED BY ME OR UNDER MY DIRECT SUPERVISION AND THAT I AM A DULY LICENSED PROFESSIONAL ENGINEER UNDER THE LAWS OF THE STATE OF MINNESOTA.

JACOB NEWHALL
 DATE: 12-05-2022 LIC. NO.: 49170

BASIN NP
 STORM SEWER

FOUR SEASONS WATER QUALITY PROJECT
 CITY OF PLYMOUTH, MN

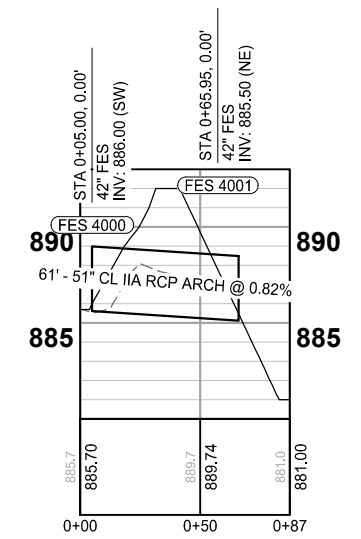
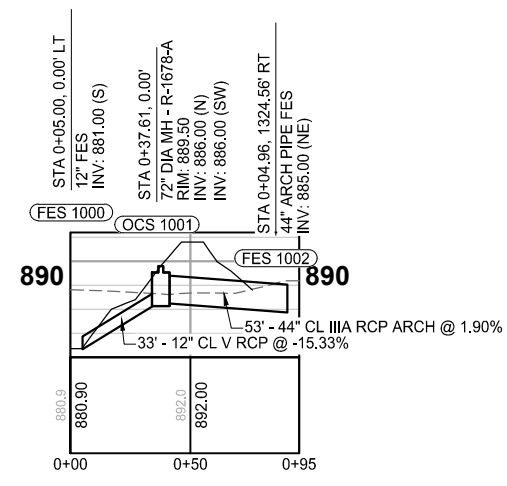

CLIENT PROJECT NO.
 WR220004

WSB PROJECT NO.
 021322-000

SHEET
 6 OF 13

STORMWATER POLLUTION PREVENTION PLAN (SWPPP) NARRATIVE

PROJECT NAME: FOUR SEASONS WATER QUALITY PROJECT **PROJECT NUMBER:** WSB 021322-000
PROJECT LOCATION: STREET: PILGRIM LN N & LANCASTER LN N CITY: PLYMOUTH COUNTY: HENNEPIN
STATE: MINNESOTA ZIP: 55447 LATITUDE/LONGITUDE: 45.03001/-93.40196

THE PLANNED SCOPE OF THE PROJECT INCLUDES:
CITY OF PLYMOUTH IS PROPOSING TO COMPLETE GRADING, UTILITY, AND STORMWATER IMPROVEMENTS AS PART OF THE FOUR SEASONS WATER QUALITY PROJECT IN PLYMOUTH MN, AS SHOWN IN THE CONSTRUCTION PLANS. THIS PROJECT INCLUDES ADDING STORMWATER PONDING AND TREATMENT FACILITIES ALONG WITH RESTORATION OF THE EXISTING ONSITE WETLAND.

CONSTRUCTION ACTIVITIES:	ESTIMATED DATES OF SOIL DISTURBANCE ACTIVITIES:
TEMPORARY SEDIMENT CONTROL BMPs & REMOVALS	January 2023
GRADING	January-March 2023
STORMWATER BMP'S	January-March 2023
FINAL STABILIZATION	May-July 2023

PROJECT PERSONNEL AND TRAINING

SWPPP DEVELOPER:
WSB (TOM HOFFMAN) 701 XENIA AVE S, SUITE 300
GOLDEN VALLEY, MN 55416
612-219-7578/THOFFMAN@WSBENG.COM

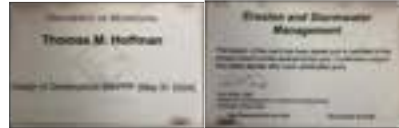

CONTRACTOR TO PROVIDE CERTIFICATION OF EROSION CONTROL OFFICER AND ANY OTHER CREW MEMBERS WHO WILL WORK ON THE IMPLEMENTATION OF THE SWPPP AND THE INSTALLATION, INSPECTION, AND MAINTENANCE OF THE EROSION PREVENTION AND SEDIMENT CONTROL BMPs BEFORE, DURING, AND AFTER CONSTRUCTION UNTIL THE NOTICE OF TERMINATION (NOT) HAS BEEN FILED WITH THE MPCA. PROVIDE PROOF OF CERTIFICATION AT THE PRECONSTRUCTION MEETING. WORK WILL NOT BE ALLOWED TO COMMENCE UNTIL PROOF OF CERTIFICATION HAS BEEN PROVIDED TO THE PROJECT ENGINEER.

CHAIN OF RESPONSIBILITY

HENNEPIN COUNTY AND THE CONTRACTOR ARE CO-PERMITTEES FOR THE NPDES CONSTRUCTION GENERAL PERMIT. THE CONTRACTOR IS RESPONSIBLE TO COMPLY WITH ALL ASPECTS OF THE NPDES CONSTRUCTION PERMIT AT ALL TIMES UNTIL THE NOTICE OF TERMINATION (NOT) HAS BEEN FILED WITH THE MPCA.

NAME	COMPANY	TITLE	PHONE
CHRIS LABOUNTY	CITY OF PLYMOUTH	CITY ENGINEER	763-509-5541

AGENCY CONTACTS

ORGANIZATION	CONTACT NAME	PHONE
MPCA (EMERGENCY) 24 HOUR	STATE DUTY OFFICER	1-800-422-0798
MPCA	BRIAN GREEN	507-206-2610
BCWMC	LAURA JESTER	952-270-1990

LOCATION OF SWPPP REQUIREMENTS

THE REQUIRED SWPPP ELEMENTS MAY BE LOCATED IN MANY PLACES WITHIN THE PLAN SET AS WELL AS IN THE SPECIAL PROVISIONS, PROJECT MANUAL, OR ON FILE WITH THE PROJECT OWNER.

DESCRIPTION	LOCATION
TEMPORARY/PERMANENT EROSION CONTROL MEASURES	TURF ESTABLISHMENT & EROSION CONTROL PLAN
DIRECTION OF FLOW	DRAINAGE PLAN
CONSTRUCTION NOTES & STANDARD PLATES	SOILS AND CONSTRUCTION NOTES & STANDARD PLATES
DRAINAGE PLAN & CONSTRUCTION PLAN	CONSTRUCTION PLAN & DRAINAGE PLAN
BMP TABULATION	TABULATIONS

RECEIVING WATERS

A SPECIAL AND IMPAIRED WATERS SEARCH WAS COMPLETED USING THE MPCA SEARCH ENGINE ON 10/25/22. BASED ON THIS REVIEW, THERE ARE NO SPECIAL/IMPAIRED WATERS (WITH CONSTRUCTION RELATED IMPAIRMENTS) ARE LOCATED WITHIN ONE MILE OF, AND DOWNSTREAM OF, ANY PROJECT DISCHARGE POINTS. PART 23.9 OF THE NPDES PERMIT APPLIES.

WATERBODY	IMPAIRED(S)
NORTHWOOD LAKE	Hg-F, NUTRIENTS
BASSETT CREEK	E. COLI (DELISTED)

STORMWATER FROM THE SITE IS COLLECTED VIA PROPOSED STORM SEWER AND DIRECTED TO STORMWATER BASINS AND WETLAND BANKING. EVENTUALLY WATER FROM THE SITE WILL MAKE ITS WAY INTO BASSETT CREEK AND NORTHWOOD LAKE. BECAUSE OF THE LOCATION THIS PROJECT AND THE PROXIMITY TO A IMPAIRED WATER BODY IT WILL BE REQUIRED TO MEET ADDITIONAL REQUIREMENTS OUTLINE IN SECTIONS 23.9, 23.10, 23.1, 23.13, AND 23.14 AS OUTLINED IN THE MINNESOTA CONSTRUCTION STORMWATER GENERAL PERMIT.

AREAS OF ENVIRONMENTAL SENSITIVITY (AES) AND INFESTED WATERS

THE CONTRACTOR SHALL BE AWARE OF ALL AREAS OF ENVIRONMENTAL SENSITIVITY ONSITE AND ADJACENT TO THE PROJECT LOCATION. THIS INCLUDES WETLANDS IDENTIFIED IN THE PLANS. LOST CREEK IS ALSO WITHIN THE PROJECT LOCATION AND WILL NEED TO BE PROTECTED DURING CONSTRUCTION. ANY WORK WITH THE PUBLIC WATERS WILL NEED TO BE PERMITTED AND FOLLOW DNR REQUIREMENTS.

WORK IN PUBLIC WATERS EXCLUSION DATES

WORK WITHIN PUBLIC WATERS MAY BE RESTRICTED DUE TO FISH SPAWNING AND MIGRATION CONCERNS. DATES OF FISH SPAWNING AND MIGRATION VARY BY SPECIES AND LOCATION THROUGHOUT THE STATE. SPECIFIC DATES FOR EACH DNR REGION MAY BE FOUND ON PAGE 4 OF CHAPTER 1 OF IN THE MANUAL: BEST PRACTICES FOR MEETING DNR GENERAL WATERS WORK PERMIT GP2004-0001.
[HTTP://WWW.DNR.STATE.MN.US/WATERS/WATERMGMT_SECTION/PWPERMITS/GP_2004_0001_MANUAL.HTML](http://www.dnr.state.mn.us/waters/watermgmt_section/pwpermits/gp_2004_0001_manual.html). WORK IN THE WATER IS NOT

ALLOWED WITHIN THESE DATES. THE DNR TRANSPORTATION HYDROLOGIST, AREA HYDROLOGIST, OR AREA FISHERIES SUPERVISOR SHALL BE CONTACTED ABOUT WAIVING WORK EXCLUSION DATES WHERE WORK IS ESSENTIAL OR WHERE MNDOT DEMONSTRATES THAT A PROJECT WILL MINIMIZE IMPACTS TO FISH HABITAT, SPAWNING, AND MIGRATION. DISCHARGE STORMWATER ASSOCIATED WITH CONSTRUCTION ACTIVITIES (PERMIT MN R10001) RECOGNIZES THE DNR "WORK IN WATER RESTRICTIONS" DURING SPECIFIED FISH MIGRATION AND SPAWNING TIME FRAMES FOR AREAS ADJACENT TO WATER. DURING THE RESTRICTION PERIOD, ALL EXPOSED SOIL AREAS THAT ARE WITHIN 200 FEET OF THE WATER'S EDGE AND DRAIN TO THESE WATERS, MUST HAVE EROSION PREVENTION STABILIZATION ACTIVITIES INITIATED IMMEDIATELY AFTER SOIL DISTURBING ACTIVITY HAS CEASED, BE COMPLETED WITHIN 24 HOURS, AND MAINTAINED FOR THE DURATION OF THE PROJECT.

SOIL TYPES

A PROJECT WIDE GEOTECHNICAL REPORT WAS COMPLETED FOR THIS PROJECT AND IS AVAILABLE BY REQUEST. EXISTING SITE CONDITIONS ARE SWAMP DEPOSITS ENCOUNTERED THROUGHOUT THE SITE BELOW EXISTING FILL. ORGANIC SOIL OF PEAT AND ORGANIC CLAY WERE GENERALLY BLACK WITH VARYING ORGANIC CONTENT.

ENVIRONMENTAL REVIEW

NO FORMAL ENVIRONMENTAL REVIEW WAS REQUIRED FOR THIS PROJECT.

WETLANDS: THERE IS ONE WETLAND WITHIN THE PROJECT AREA, AS PART OF THE PROJECT THERE IS 2.35 AC OF PROPOSED TEMPORARY WETLAND IMPACTS AS PART OF THE PROJECT, THERE ARE ALSO 2.19 OF PROPOSED PERMANENT WETLAND IMPACT. THE PROPOSED PERMANENT IMPACTS ARE PART OF A WETLAND RESTORATION AND WILL BE CREDITED TOWARDS THE PROJECT. IF THERE IS ANY ADDITIONAL WETLAND IMPACTS THE PROJECT WILL GO THROUGH THE WCA PROCESS BEFORE ANY MORE FILL. ADJACENT OFFSITE WETLANDS WILL BE PROTECTED DURING THE PROJECT.

THREATENED/ENDANGERED SPECIES: HENNEPIN COUNTY LISTS THE NORTHERN LONG-EARED BAT, RUSTY-PATCHED BUMBLE BEE, MONARCH BUTTERFLY, AND BLANDING'S TURTLE AS SPECIES OF CONCERN. BASED ON CONSTRUCTION ACTIVITIES AND HABITAT MAPPING, IT IS DETERMINED THAT THE PROJECT WILL HAVE NO EFFECT ON THESE SPECIES OR THEIR HABITATS. HOWEVER, IF THIS SPECIES IS FOUND, CONTRACTOR TO STOP WORK IMMEDIATELY FOR FURTHER INVESTIGATION.

DRINKING WATER/WELLS: ACCORDING TO THE MDH, THE PROJECT IS NOT LOCATED WITHIN A DRINKING WATER SUPPLY MANAGEMENT AREA (DWSMA). SPECIAL CARE MUST STILL BE TAKEN WHEN RESPONDING TO SPILLS ON SITE AND HANDLING HAZARDOUS MATERIALS, SUCH AS CONCRETE WASHOUT, FUELING OPERATIONS, ETC. SO THAT THE DRINKING SUPPLY DOES NOT BECOME CONTAMINATED. AT THE DISCRETION OF THE PROJECT ENGINEER, A WELLHEAD PROTECTION PLAN MAY BE DEVELOPED AND SUBMITTED AND/OR VERIFICATION OF WELL LOCATION PRIOR TO WORK BEGINNING.

CONTAMINATED PROPERTIES: THE MPCA'S "WHAT'S IN MY NEIGHBORHOOD" DATABASE WAS REVIEWED ON 10/27/22. THE RESULTS OF THIS REVIEW SHOW THERE ARE NO KNOWN CONTAMINATED SITES WITHIN OR ADJACENT TO THE PROJECT AREA. THE DEPTH OF THE GRADING IS NOT PROPOSED TO UNEARTH ANY CONTAMINATED SOIL, CONTAMINATED WATER, AND/OR REGULATED WASTE. REFER TO MNDOT SPEC 1717.1.A. FOR POTENTIAL INDICATORS OF CONTAMINATED MATERIALS AND REGULATED WASTE. IF CONTAMINATED MATERIAL, CONTAMINATED WATER, AND/OR REGULATED MATERIALS ARE FOUND, CREWS ARE TO STOP WORK IMMEDIATELY FOR FURTHER INVESTIGATION/TESTING.

FLOOD CONTINGENCY PLAN: PROJECT ACTIVITIES ARE NOT LOCATED WITHIN THE 100-YEAR FLOODPLAIN OR FLOODWAY; HOWEVER, THE PROJECT ENGINEER (AT THEIR DISCRETION) MAY REQUIRE A PREVENTATIVE FLOOD CONTINGENCY PLAN FOR SPECIFIC PROJECT ACTIVITIES AND AREAS IF SEASONAL PRECIPITATION POSSES A POTENTIAL RISK OF FLOODING WORK AREAS WITHIN THE PROJECT LIMITS. THIS PLAN SHALL BE SUBMITTED BY THE OPERATOR TO THE PROJECT ENGINEER FOR APPROVAL A MINIMUM OF 72 HOURS PRIOR TO THE SCHEDULED WORK AND/OR DURING ACTIVE WORK WITHIN THE AREA OF POTENTIAL RISK OF FLOODING. NO WORK CAN COMMENCE IN THE AREA UNTIL WRITTEN APPROVAL HAS BEEN GRANTED BY THE PROJECT ENGINEER.

ESTIMATED EROSION CONTROL QUANTITY

EROSION & SEDIMENT CONTROL BMP	UNIT	QUANTITY
SILT FENCE (MS)	LF	113
BIOLOG	LF	1,019
INLET PROTECTION	EACH	8
ROCK CONSTRUCTION EXIT	EACH	2
EROSION CONTROL BLANKET CAT 3N	SF	50,280

LAND FEATURE CHANGES

TOTAL AREA TO BE DISTURBED = 4.37 ACRES
IMPERVIOUS AREA: PRE-CONSTRUCTION = 7,770 SF/POST-CONSTRUCTION = 687 SF
NET DECREASE OF IMPERVIOUS AREA = 7,083 SF

LONG TERM MAINTENANCE AND OPERATION: THE NPDES PERMANENT STORMWATER TREATMENT SYSTEM (PART 15.1) IS NOT REQUIRED BECAUSE THERE IS LESS THAN AN ACRE NEW IMPERVIOUS AREA CREATED BY THE FUTURE BUILDING PROJECT.

STABILIZATION TIME FRAMES

AREA	TIME FRAME	NOTES
EXPOSED AREAS	IMMEDIATELY AND NO LATER THAN 7 DAYS OF BEING UNWORKED	1, 4, 5
LAST 200 LINEAL FEET OF DRAINAGE DITCH/SWALE	WITHIN 24 HOURS OF CONNECTION TO SURFACE WATER/PROPERTY EDGE	1, 2, 3
REMAINING PORTIONS OF DRAINAGE DITCH OR SWALE	7 DAYS	1, 3
PIPE AND CULVERT OUTLETS	24 HOURS	
STOCKPILES	7 DAYS	1

SCALE: DESIGN BY:
AS SHOWN SML
PLAN BY: CHECK BY:
LGR JHN

NO.	DATE	DESCRIPTION

I HEREBY CERTIFY THAT THIS PLAN, SPECIFICATION, OR REPORT WAS PREPARED BY ME OR UNDER MY DIRECT SUPERVISION AND THAT I AM A DULY LICENSED PROFESSIONAL ENGINEER UNDER THE LAWS OF THE STATE OF MINNESOTA.

JACOB NEWMALL
DATE: 11-23-2022 LIC. NO.: 49170

SWPPP NARRATIVE 1

FOUR SEASONS WATER QUALITY PROJECT
CITY OF PLYMOUTH, MN

CLIENT PROJECT NO.
WR220004

WSB PROJECT NO.
021322-000

SHEET

7 OF 13

- INITIATE STABILIZATION IMMEDIATELY WHEN CONSTRUCTION HAS TEMPORARILY OR PERMANENTLY CEASED ON ANY PORTION OF THE SITE. COMPLETE STABILIZATION WITHIN THE TIME FRAME LISTED. IN MANY INSTANCES THIS WILL REQUIRE STABILIZATION TO OCCUR MORE THAN ONCE DURING THE COURSE OF THE PROJECT. TEMPORARY SOIL STOCKPILES WITHOUT SIGNIFICANT CLAY OR SILT AND STOCKPILED AND CONSTRUCTED ROAD BASE ARE EXEMPT FROM THE STABILIZATION REQUIREMENT.
- STABILIZE WETTED PERIMETER OF DITCH (I.E. WHERE THE DITCH GETS WET).
- APPLICATION OF MULCH, HYDROMULCH, TACKIFIER AND POLYACRYLAMIDE ARE NOT ACCEPTABLE STABILIZATION METHODS IN THESE AREAS.
- STABILIZE ALL AREAS OF THE SITE PRIOR TO THE ONSET OF WINTER. ANY WORK STILL BEING PERFORMED WILL BE MULCHED OR BLANKETED WITHIN THE TIME FRAMES IN THE NPDES PERMIT.
- KEEP DITCHES AND EXPOSED SOILS IN AN EVEN ROUGH GRADED CONDITION IN ORDER TO BE ABLE TO APPLY EROSION CONTROL MULCHES, HYDROMULCHES, AND BLANKETS.

SITE INSPECTION AND MAINTENANCE

THE EROSION CONTROL OFFICER IS TO INSPECT THE ENTIRE CONSTRUCTION SITE AT LEAST ONCE EVERY SEVEN (7) DAYS DURING ACTIVE CONSTRUCTION AND WITHIN 24 HOURS AFTER A RAINFALL EVENT GREATER THAN 0.5 INCHES IN 24 HOURS. THE OPERATOR SHALL PROVIDE A RAINFALL GAUGE ON-SITE AT VARIOUS MILE INTERVALS ALONG THE ALIGNMENT. INSPECT ALL TEMPORARY AND PERMANENT PROJECT BMPS UNTIL THE SITE HAS UNDERGONE FINAL STABILIZATION AND THE NOT HAS BEEN SUBMITTED. INSPECT SURFACE WATER INCLUDING DRAINAGE DITCHES FOR SIGNS OF EROSION AND SEDIMENT DEPOSITION. INSPECT CONSTRUCTION SITE VEHICLE EXIT LOCATIONS FOR EVIDENCE OF TRACKING ONTO PAVED SURFACES. INSPECT SURROUNDING PROPERTIES FOR EVIDENCE OF OFF-SITE SEDIMENT ACCUMULATION. ALL INSPECTIONS AND MAINTENANCE CONDUCTED MUST BE RECORDED IN WRITING BY THE OPERATOR AND RETAINED WITH THE SWPPP. SUBMIT INSPECTION REPORTS IN A FORMAT THAT IS ACCEPTABLE TO THE PROJECT ENGINEER. RECORDS OF EACH INSPECTION AND MAINTENANCE ACTIVITY SHALL INCLUDE:

- DATE, TIME, AND NAME OF PERSON(S) CONDUCTING INSPECTIONS;
- FINDINGS OF INSPECTIONS, INCLUDING RECOMMENDATIONS FOR CORRECTIVE ACTIONS;
- CORRECTIVE ACTIONS TAKEN (INCLUDING DATES, TIMES, AND PARTY COMPLETING MAINTENANCE ACTIVITIES); INCLUDING DOCUMENTATION/PHOTOS OF IMPLEMENTED BMPS INTENDED TO CORRECT A PROBLEM BUT FAILED.
- DATE AND AMOUNT OF ALL RAINFALL EVENTS GREATER THAN 0.5 INCHES IN 24 HOURS;
- DOCUMENTATION OF CHANGES MADE TO THE SWPPP.

REPLACE, REPAIR OR SUPPLEMENT ALL NONFUNCTIONAL BMPS BY THE END OF THE NEXT BUSINESS DAY FOLLOWING DISCOVERY UNLESS LISTED DIFFERENTLY BELOW:

- REPAIR, REPLACE, OR SUPPLEMENT PERIMETER CONTROL DEVICES WHEN THEY BECOME NONFUNCTIONAL OR SEDIMENT REACHES 1/2 THE HEIGHT OF THE DEVICE. COMPLETE REPAIRS BY THE END OF THE NEXT BUSINESS DAY FOLLOWING DISCOVERY.
- REPAIR OR REPLACE INLET PROTECTION DEVICES WHEN THEY BECOME NONFUNCTIONAL OR SEDIMENT REACHES 1/2 THE HEIGHT AND/OR DEPTH OF THE DEVICE.
- REMOVE ALL DELTAS AND SEDIMENT DEPOSITED IN SURFACE WATERS INCLUDING DRAINAGE WAYS, CATCH BASINS, AND OTHER DRAINAGE SYSTEMS. STABILIZE ANY AREAS THAT ARE DISTURBED BY SEDIMENT REMOVAL OPERATIONS. SEDIMENT REMOVAL AND STABILIZATION MUST BE COMPLETED WITHIN 7 DAYS OF DISCOVERY.
- REMOVE TRACKED SEDIMENT FROM PAVED SURFACES BOTH ON AND OFF SITE WITHIN ONE (1) CALENDAR DAY OF DISCOVERY. STREET SWEEPING MAY HAVE TO OCCUR MORE OFTEN TO MINIMIZE OFF SITE IMPACTS. LIGHTLY WET THE PAVEMENT PRIOR TO SWEEPING.
- MAINTAIN ALL BMPS UNTIL WORK HAS BEEN COMPLETED, SITE HAS GONE UNDER FINAL STABILIZATION, AND THE NOT HAS BEEN SUBMITTED TO THE MPCA.

CONSTRUCTION ACTIVITY REQUIREMENTS: EROSION/SEDIMENT CONTROL, PROCEDURES, & MAINTENANCE STANDARDS

- AMEND THE SWPPP AND DOCUMENT ALL CHANGES TO THE SWPPP AND ASSOCIATED PLAN SHEETS IN A TIMELY MANNER. SWPPP AMENDMENTS AND SITE PLANS WILL BE PREPARED BY THE OPERATOR AND SUBMITTED TO THE OWNER FOR REVIEW AND WRITTEN APPROVAL BY THE PROJECT OWNER (OR DESIGNATED REPRESENTATIVE). STORE THE SWPPP AND ALL AMENDMENTS ON SITE AT ALL TIMES.
- PREPARE AND SUBMIT A SITE MANAGEMENT PLAN FOR THE ENGINEER'S ACCEPTANCE FOR WORK IN AND NEAR AREAS OF ENVIRONMENTAL SENSITIVITY, AREAS IDENTIFIED IN THE PLANS AS "SITE MANAGEMENT PLAN AREA", ANY WORK THAT WILL REQUIRE DEWATERING, ANY ADDITIONAL PLANS LISTED IN THE PROJECT SPECIFICATIONS, AND AS REQUIRED BY THE ENGINEER. SUBMIT ALL SITE MANAGEMENT PLANS TO THE ENGINEER IN WRITING. ALLOW A MINIMUM OF 7 DAYS FOR PROJECT ENGINEER TO REVIEW AND ACCEPT SITE MANAGEMENT PLAN SUBMITTALS. WORK WILL NOT BE ALLOWED TO COMMENCE IF A SITE MANAGEMENT PLAN IS REQUIRED UNTIL ACCEPTANCE HAS BEEN GRANTED BY THE ENGINEER. THERE WILL BE NO EXTRA TIME ADDED TO THE CONTRACT DUE TO THE UNTIMELY SUBMITTAL.
- THERE IS NO CONSTRUCTION PHASING OR STAGING DEFINED BY THE OWNER FOR THIS PROJECT. THE SCHEDULE FOR INSTALLING TEMPORARY BMPS SHALL BE INCORPORATED INTO THE OPERATOR'S WEEKLY SCHEDULE FOR EACH CONSTRUCTION STAGE AND PRESENTED TO THE OWNER'S REPRESENTATIVE.
- BURNING OF ANY MATERIAL IS NOT ALLOWED WITHIN PROJECT BOUNDARY.
- DO NOT DISTURB AREAS OUTSIDE OF THE CONSTRUCTION LIMITS. DELINEATE AREAS NOT TO BE DISTURBED AND WETLANDS (EVEN AREAS THAT ARE PERMITTED FOR CONSTRUCTION) PRIOR TO STARTING GROUND DISTURBING ACTIVITIES. IF IT BECOMES NECESSARY TO DISTURB AREAS OUTSIDE OF THE CONSTRUCTION LIMITS, OBTAIN WRITTEN PERMISSION FROM THE PROJECT ENGINEER PRIOR TO PROCEEDING. PRESERVE ALL NATURAL BUFFERS SHOWN ON THE PLANS.
- ROUTE STORMWATER AROUND UNSTABILIZED AREAS OF THE SITE WHENEVER FEASIBLE. PROVIDE EROSION CONTROL AND VELOCITY DISSIPATION DEVICES AS NEEDED TO KEEP CHANNELS FROM ERODING AND TO PREVENT NUISANCE CONDITIONS AT THE OUTLET.
- DIRECT DISCHARGE FROM BMPS TO VEGETATED AREAS WHENEVER FEASIBLE. PROVIDE VELOCITY DISSIPATION DEVICES AS NEEDED TO PREVENT EROSION.
- LOCATE PERIMETER CONTROL ON THE CONTOUR TO CAPTURE OVERLAND, LOW-VELOCITY SHEET FLOWS DOWN GRADIENT OF ALL EXPOSED SOILS AND PRIOR TO DISCHARGING TO SURFACE WATERS. PLACE J-HOOKS AT A MAXIMUM OF 100-FOOT INTERVALS.
- ALL STOCKPILES MUST HAVE PERIMETER SEDIMENT CONTROLS IMPLEMENTED AND MAINTAINED AT ALL TIMES. PILES CANNOT BE PLACED IN BUFFER AREAS OR SURFACE WATERS, INCLUDING STORMWATER CONVEYANCES SUCH AS CURB AND GUTTER SYSTEMS, OR CONDUITS AND DITCHES UNLESS THERE IS A BYPASS IN PLACE TO PREVENT STORMWATER RUN-ON INTO THE STOCKPILE.
- STEEP SLOPES MAY BE TEMPORARILY CREATED DURING GRADING OPERATIONS. STABILIZATION OF STEEP SLOPES (3:1 OR GREATER) SHALL BE PROPERLY CAT-TRACKED AND STABILIZED PER THE EROSION CONTROL PLAN. LONG SLOPES CAN BE BROKEN UP WITH SEDIMENT CONTROL LOGS IF EROSION IS EVIDENT.
- DITCH CHECKS WILL BE PLACED AS INDICATED ON THE PLANS DURING ALL PHASES OF CONSTRUCTION.
- ALL STORM DRAIN INLETS, THAT RECEIVE PROJECT STORMWATER, MUST BE PROTECTED BY APPROPRIATE BMPS DURING CONSTRUCTION UNTIL ALL SOURCES WITH POTENTIAL FOR DISCHARGING TO THE INLET HAVE BEEN STABILIZED. INLET PROTECTION MAY BE

REMOVED FOR A PARTICULAR INLET IF A SPECIFIC SAFETY CONCERN (STREET FLOODING/FREEZING) HAS BEEN IDENTIFIED AND THE PERMITTEE(S) HAS RECEIVED WRITTEN CORRESPONDENCE FROM THE JURISDICTIONAL AUTHORITY VERIFYING THE NEED FOR REMOVAL. WRITTEN CORRESPONDENCE MUST BE DOCUMENTED IN THE SWPPP.

- SILT FENCE IS NOT AN ACCEPTABLE CATCH BASIN INLET PROTECTION BMP. CONTACTOR SHALL CLEAN, REMOVE AND DISPOSE OF SEDIMENT, AND/OR REPLACE STORM DRAIN INLET PROTECTION ON A ROUTINE BASIS TO ENSURE THE DEVICE IS FULLY FUNCTIONAL PRIOR TO THE NEXT FORECASTED PRECIPITATION EVENT (30% OR GREATER).
- DEWATERING DISCHARGE TURBID OR SEDIMENT LADEN WATER TO TEMPORARY SEDIMENT BASINS WHENEVER FEASIBLE. IN THE EVENT THAT IT IS NOT FEASIBLE TO DISCHARGE THE SEDIMENT LADEN WATER TO A TEMPORARY SEDIMENT BASIN, THE WATER MUST BE TREATED SO THAT IT DOES NOT CAUSE A NUISANCE CONDITION IN THE RECEIVING WATERS OR TO DOWNSTREAM LANDOWNERS. CLEAN OUT ALL PERMANENT STORMWATER BASINS REGARDLESS OF WHETHER USED AS TEMPORARY SEDIMENT BASINS/TRAPS TO THE DESIGN CAPACITY AFTER COMPLETING ALL UP-GRADIENT LAND DISTURBING ACTIVITY. USE A SKIMMER DEVICE FOR BASIN DRAINING.
- PROVIDE STABILIZATION IN ANY TRENCHES CUT FOR DEWATERING OR SITE DRAINING PURPOSES.
- THE CONTRACTOR SHALL SUBMIT A DEWATERING PLAN AND NARRATIVE TO THE PROJECT ENGINEER FOR APPROVAL 7 DAYS PRIOR TO UNDERTAKING THESE ACTIVITIES. DEWATERING PLAN MUST INCLUDE BMP'S TO PREVENT SEDIMENT TRANSPORT, EROSION, AND ADVERSE IMPACTS TO DOWNSTREAM RECEIVING WATERS. THE DEWATERING PLAN MUST ALSO INCLUDE ANY SPECIFIC CHEMICAL TREATMENTS (FLOC, POLYMERS, ETC.) THAT WILL BE USED. THE CONTRACTOR IS RESPONSIBLE TO OBTAIN ANY PERMIT NECESSARY FOR THESE ACTIVITIES; THE DEWATERING PLAN AND DNR APPROPRIATIONS PERMIT WILL BECOME PART OF THE SWPPP.
- EFFORTS SHOULD BE MADE TO PRESERVE TOPSOIL AND MINIMIZE COMPACTION ON THE PROJECT SITE.

TEMPORARY & PERMANENT EROSION CONTROL BMPS

SEED MIX: SEED MIX SHALL BE USED IN CONSTRUCTION AND REVEGETATION PROJECTS IN ORDER TO ENHANCE SOIL NUTRIENT AVAILABILITY AND BIOLOGICAL SOIL STRUCTURE, ENCOURAGE NATIVE PLANT SUCCESSION, REDUCE EROSION, AND DISCOURAGE INVASIVE PLANT SPECIES. INOCULATION OF SOILS WITH MYCORRHIZAL FUNGI OR THE PRESENCE OF PRE-EXISTING SOIL MICROBES IS ESSENTIAL FOR THE STABILIZATION OF ADVERSE SOILS, ESTABLISHMENT OF NATIVE GRASSES, AND THE EXCLUSION OF NON-NATIVE "ANNUALS" AND NOXIOUS WEEDS.

EROSION CONTROL BLANKET: EROSION CONTROL BLANKETS (ECBS) ARE A SOIL STABILIZATION (EROSION CONTROL) BMP, INTENDED TO PROTECT DISTURBED SOIL SURFACES FROM RAINDROP IMPACT EROSION. ECBS ARE CARPET-LIKE MATS, INSTALLED OVER AND ANCHORED TO THE PROPERLY PREPARED SOIL SURFACES. PROPERLY SELECTED AND INSTALLED, ECBS CAN MIMIC THE BENEFICIAL EFFECTS OF VEGETATIVE COVER THEREBY REDUCING EROSION RATES BY OVER 90%. ECBS ALSO PROTECT SEEDS AND PROVIDE A BENEFICIAL ENVIRONMENT FOR VEGETATION TO BECOME ESTABLISHED. CONTRACTOR SHALL VERIFY DURING REGULAR INSPECTIONS THAT NO GULLIES, RILLS, OR SCOUR HOLES HAVE FORMED UNDER EROSION CONTROL BLANKETS AND MATS AND CORRECT ALL ERODED AREAS WITHIN 7 DAYS. ALL REPAIRS MUST BE COMPLETED WITHIN 24 HOURS OF DISCOVERY, OR AS SOON AS FIELD CONDITIONS ALLOW ACCESS.

STRAW MULCHING: DISTURBED SOIL AREAS SHALL BE PROTECTED WITH STRAW MULCH. MULCHING IS THE APPLICATION OF A PROTECTIVE LAYER OF STRAW OR OTHER SUITABLE MATERIAL TO THE SOIL SURFACE. STRAW MULCH SHALL BE USED IN CONJUNCTION WITH SEEDING AND HYDRO-SEEDING FOR ESTABLISHMENT OF VEGETATION. STRAW MULCH MUST BE SECURED TO THE GROUND USING DISKING OR AN OVERSPRAY OF AN HECP. MULCHING IS COMMONLY USED AS A TEMPORARY MEASURE TO PROTECT BARE OR DISTURBED SOIL AREAS THAT HAVE NOT BEEN SEEDED, UNTIL NATIVE VEGETATION RE-GROWS. CERTIFIED WEED-FREE MULCH MUST BE USED WHEN USING NATIVE SEED MIXES OR WHEN WORKING NEAR ENVIRONMENTALLY SENSITIVE AREAS.

HYDRAULIC MATRICES: HYDRAULIC MATRICES ARE EROSION CONTROL PRODUCTS THAT ARE USED TO STABILIZE EXPOSED SOILS. THESE MATRICES ARE APPLIED IN A SLURRY, PRODUCED BY MIXING FIBER, WATER AND A BINDING AGENT TOGETHER IN A MECHANICAL HYDRO-SEEDER. WOOD FIBER IS WIDELY USED BUT OTHER FIBERS CAN INCLUDE PAPER, STRAW, COIR, CORN, ETC. THE EFFECTIVENESS OF THESE HYDRAULIC MATRICES ARE DEPENDENT ON:

- PROPER SOIL PREPARATION
- APPLICATION RATES (DEPENDENT ON THE MANUFACTURERS RECOMMENDATIONS)
- THE TYPE OF FIBERS USED
- THE TYPE OF BOND AGENT(S) ADDED

THESE HYDRAULIC MATRICES ARE CLASSIFIED IN THE MNDOT SPEC BOOK AND APPROVED PRODUCTS LIST, DEPENDING ON THE PRODUCT CHARACTERISTICS, STRENGTH, AND LONGEVITY. HYDRAULIC MATRICES USED INCLUDE: ORGANIC FIBER MATRIX, HYDRAULIC MULCH MATRIX, STABILIZED FIBER MATRIX, BONDED FIBER MATRIX, AND FIBER REINFORCED MATRIX.

ENERGY DISSIPATER: AN ENERGY DISSIPATER IS A STRUCTURE DESIGNED TO CONTROL EROSION AT THE OUTLET OF A CHANNEL OR CONDUIT.

TEMPORARY & PERMANENT SEDIMENT CONTROL BMPS

SEDIMENT CONTROL LOGS: SEDIMENT CONTROL LOGS ARE MANUFACTURED FROM STRAW, WOOD EXCELSIOR, COCONUT FIBERS, AND/OR OTHER MATERIALS THAT ARE BOUND WITH POLYPROPYLENE OR BIODEGRADABLE NETTING INTO TIGHT TUBULAR ROLLS. FIBER ROLLS CONTROL THREE TYPES OF EROSIONAL PROCESSES; EROSION CONTROL, RUN OFF CONTROL, AND SEDIMENT CONTROL. SEDIMENT CONTROL LOGS CAN BE USED FOR THE FOLLOWING:

- SLOPE INTERRUPTERS TO REDUCE EROSION ON NEWLY CONSTRUCTED SLOPES
- TEMPORARY DITCH CHECKS TO REDUCE RUNOFF VELOCITIES IN DRAINAGE CHANNELS
- SEDIMENT CONTROL BARRIERS FOR SMALL DISTURBED SOIL AREAS SUCH AS STOCKPILES, DISCRETE SLOPES, OR INDIVIDUAL LOTS

MACHINE SLICED SILT FENCE: A SILT FENCE IS A TEMPORARY SEDIMENT BARRIER CONSISTING OF FILTER FABRIC ENTRENCHED INTO THE SOIL AND ATTACHED TO SUPPORTING POSTS. SILT FENCE IS INTENDED TO BE INSTALLED WHERE SEDIMENT-LADEN WATER CAN POND, THUS ALLOWING THE SEDIMENT TO FALL OUT OF SUSPENSION AND SEPARATE FROM THE RUNOFF. SILT FENCE INSTALLED WITH A TRENCHER OR BY SLICING IS THE MOST EFFECTIVE INSTALLATION METHOD TO ENSURE AGAINST COMMON SILT FENCE FAILURES. THE BMP WILL BE CLEANED OUT OR REPLACED WHEN THE SEDIMENT REACHES 1/2 THE HEIGHT OF THE FENCE.

STABILIZED CONSTRUCTION EXIT: TEMPORARY CONSTRUCTION EXITS ARE CONSTRUCTED AT THE EGRESS POINT FROM THE CONSTRUCTION AREA ONTO A PAVED ROAD. A STABILIZED CONSTRUCTION EXIT IS A TRACKING CONTROL BMP INTENDED TO PREVENT TRACKING OF SOIL FROM THE CONSTRUCTION SITE BY EQUIPMENT AND VEHICLES. THE EXITS ARE CONSTRUCTED OF LARGE ANGULAR ROCK, STEEL RIBS (RUMBLE STRIPS), OR TRACK PADS INTENDED TO KNOCK THE MUD OFF THE TIRES BEFORE TRAVELING ONTO THE ROADWAY.

SCALE: AS SHOWN LGR
DESIGN BY: SML
CHECK BY: JHN

NO.	DATE	DESCRIPTION

I HEREBY CERTIFY THAT THIS PLAN SPECIFICATION, OR REPORT WAS PREPARED BY ME OR UNDER MY DIRECT SUPERVISION AND THAT I AM A DULY LICENSED PROFESSIONAL ENGINEER UNDER THE LAWS OF THE STATE OF MINNESOTA.

JACOB NEUHAL
DATE: 11-23-2022 LIC. NO.: 49170

SWPPP NARRATIVE 2

FOUR SEASONS WATER QUALITY PROJECT
CITY OF PLYMOUTH, MN

CLIENT PROJECT NO. WR220004

WSB PROJECT NO. 021322-000

SHEET 8 OF 13

CHEMICAL TREATMENTS: OPERATOR MUST AMEND THE SWPPP TO INCLUDE THE INTENDED USES AND LOCATIONS OF FLOCCULANTS, POLYMERS, AND OTHER SEDIMENTATION TREATMENT CHEMICALS. CHEMICAL TREATMENTS MUST BE IN COMPLIANCE WITH PART 9.18.

DUST CONTROL: OPERATOR WILL COMPLY WITH STATE RULE 7011.0150 ON DUST PREVENTION REQUIREMENTS. DUST FROM THE SITE WILL BE CONTROLLED BY INCREASED STREET SWEEPING AND/OR USING A MOBILE PRESSURE-TYPE DISTRIBUTOR TRUCK TO APPLY POTABLE WATER TO DISTURBED AREAS. THE MOBILE UNIT WILL APPLY WATER AT A RATE NECESSARY TO PREVENT RUNOFF AND PONDING.

POLLUTION PREVENTION MANAGEMENT

POTENTIAL SOURCES OF POLLUTANTS FROM CONSTRUCTION ACTIVITIES INCLUDE, BUT NOT LIMITED TO:

1. SEDIMENT AND FUGITIVE DUST GENERATED FROM CLEARING AND GRUBBING, IMPORT/EXPORT OPERATIONS, REMOVALS/COMPACTION, MASS/FINE GRADING, EXCAVATIONS, TRENCHING, TOPSOIL STRIPING STOCKPILING.
 2. EXCESS NUTRIENTS FROM SOIL ADDITIVES, FERTILIZATION, MULCHING.
- OPERATOR WILL COMPLY WITH ALL OF THE POLLUTION PREVENTION AND MANAGEMENT MEASURES IDENTIFIED IN THE NPDES-CSW PERMIT, PART 12.1. STORAGE AND DISPOSAL OF CONSTRUCTION AND HAZARDOUS WASTES MUST BE IN COMPLIANCE WITH MPCA REGULATIONS.
- A. POSITION AND STAKE DOWN ALL PORTABLE TOILETS SO THEY CANNOT BE TIPPED OR KNOCKED OVER. SUPPLY ADEQUATE SECONDARY CONTAINMENT.
 - B. SECONDARY CONTAINMENT IS NEEDED AROUND ALL STATIONARY EQUIPMENT (GENERATORS, PUMPS, LIGHT PLANTS, ETC.) PROVIDE CONTAINMENT FOR ALL HAZARDOUS MATERIALS AND TOXIC WASTE.
 - C. NO ENGINE DEGREASING IS ALLOWED ON SITE.
 - D. VEHICLE AND EQUIPMENT WASHING TO OCCUR IN DESIGNATED AREA AS DETERMINED BY THE CONTRACTOR SUBMITTAL OF A MANAGEMENT PLAN FOR THESE ACTIVITIES.
 - E. PROPERLY CLEAN UP AND REPORT ALL SPILLS AS REQUIRED BY THE MPCA AND MNDOT SPECIFICATIONS.
 - F. PROVIDE A SPILL KIT AT EACH WORK LOCATION ON THE SITE.
 - G. PROVIDE A SECURE STORAGE AREA WITH RESTRICTED ACCESS FOR ALL HAZARDOUS MATERIALS AND TOXIC WASTE. RETURN ALL HAZARDOUS MATERIALS AND TOXIC WASTE TO THE DESIGNATED STORAGE AREA AT THE END OF THE BUSINESS DAY UNLESS INFEASIBLE. STORE ALL HAZARDOUS MATERIALS AND TOXIC WASTE (INCLUDING BUT NOT LIMITED TO OIL, DIESEL FUEL, GASOLINE, HYDRAULIC FLUIDS, PAINT, PETROLEUM BASED PRODUCTS, WOOD PRESERVATIVES, ADDITIVES, CURING COMPOUNDS, AND ACIDS) IN SEALED CONTAINERS WITH SECONDARY CONTAINMENT. CLEAN UP SPILLS IMMEDIATELY. STORE, COLLECT AND DISPOSE OF ALL SOLID WASTE.
 - H. SLURRY FROM CONCRETE OPERATIONS MUST BE VACUUMED UP IMMEDIATELY. NO CONCRETE WASHOUT SHALL COME IN CONTACT WITH THE GROUND AND MUST BE PROPERLY DISPOSED OF.
 - I. A SIGN MUST BE INSTALLED ADJACENT TO EACH CONCRETE WASHOUT FACILITY.
 - J. CREATE AND FOLLOW A WRITTEN DISPOSAL PLAN FOR ALL WASTE MATERIALS. INCLUDE IN THE PLAN HOW THE MATERIAL WILL BE DISPOSED OF AND THE LOCATION OF THE DISPOSAL SITE. SUBMIT PLAN TO THE ENGINEER PRIOR TO CONSTRUCTION.

- K. USE METHODS AND OPERATIONAL PROCEDURES THAT PREVENT DISCHARGE OR PLACEMENT OF BITUMINOUS GRINDINGS, CUTTINGS, AND OTHER BITUMINOUS WASTES FROM AREAS OF EXISTING OR FUTURE VEGETATED SOILS AND FROM ALL WATER CONVEYANCE SYSTEMS, INCLUDING INLETS, DITCHES AND CURB FLOW LINES.
- L. PORTABLE TOILETS MUST BE AT LEAST TWENTY-FIVE FEET FROM STORM INLETS OR RECEIVING WATERS.

FINAL STABILIZATION

FINAL STABILIZATION IS ACHIEVED WHEN NPDES CGP PARTS 13.1-13.7 (AS APPLICABLE) ARE COMPLETED PRIOR TO SUBMISSION OF THE NOTICE OF TERMINATION (NOT) TO MPCA.

1. ALL AREAS MUST BE STABILIZED WITH A UNIFORM PERENNIAL VEGETATIVE COVER WITH A DENSITY OF 70%.
2. ALL TEMPORARY SEDIMENT CONTROL BMP MEASURES MUST BE REMOVED PRIOR TO SUBMITTING PERMIT NOT.
3. PERMANENT STORMWATER SYSTEM IS CONSTRUCTED, MEETS ALL REQUIREMENTS, IS FREE OF ACCUMULATE CONSTRUCTION SEDIMENT, AND IS OPERATING AS DESIGNED.

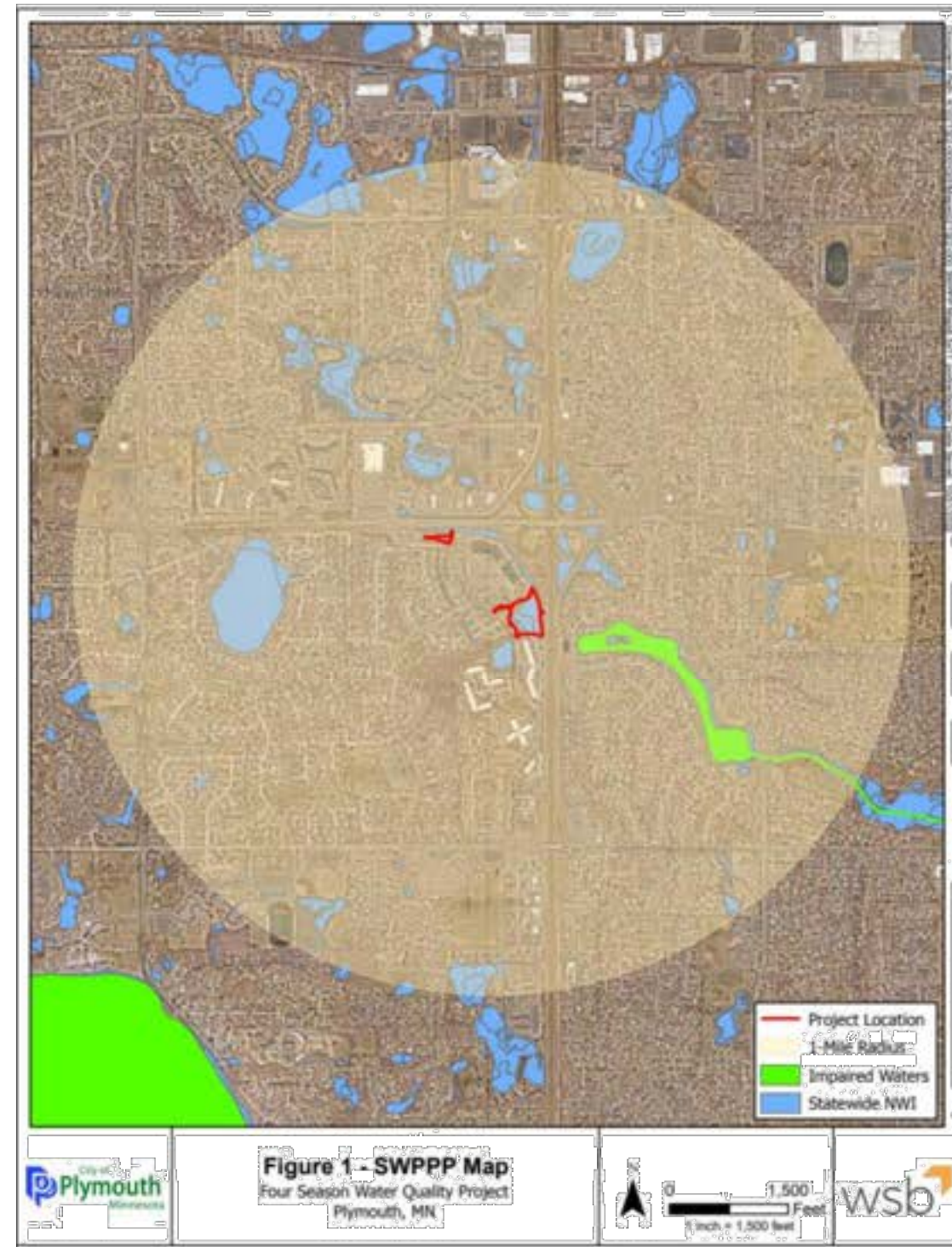

SCALE: AS SHOWN LGR
 DESIGN BY: SML
 CHECK BY: JHN

REVISIONS	
NO.	DESCRIPTION

I HEREBY CERTIFY THAT THIS PLAN, SPECIFICATION, OR REPORT WAS PREPARED BY ME OR UNDER MY DIRECT SUPERVISION AND THAT I AM A DULY LICENSED PROFESSIONAL ENGINEER UNDER THE LAWS OF THE STATE OF MINNESOTA.

JACOB NEUHALL
 DATE: 11-23-2022 LIC. NO.: 49170

SWPPP NARRATIVE 3

**FOUR SEASONS WATER QUALITY PROJECT
 CITY OF PLYMOUTH, MN**

CLIENT PROJECT NO. WR220004

WSB PROJECT NO. 021322-000

SHEET

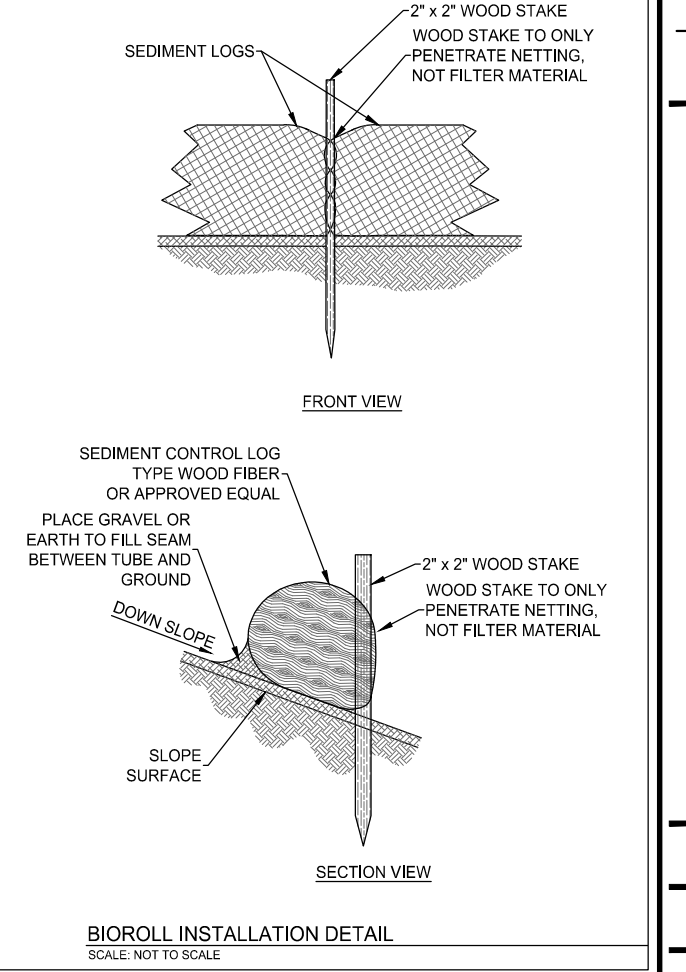
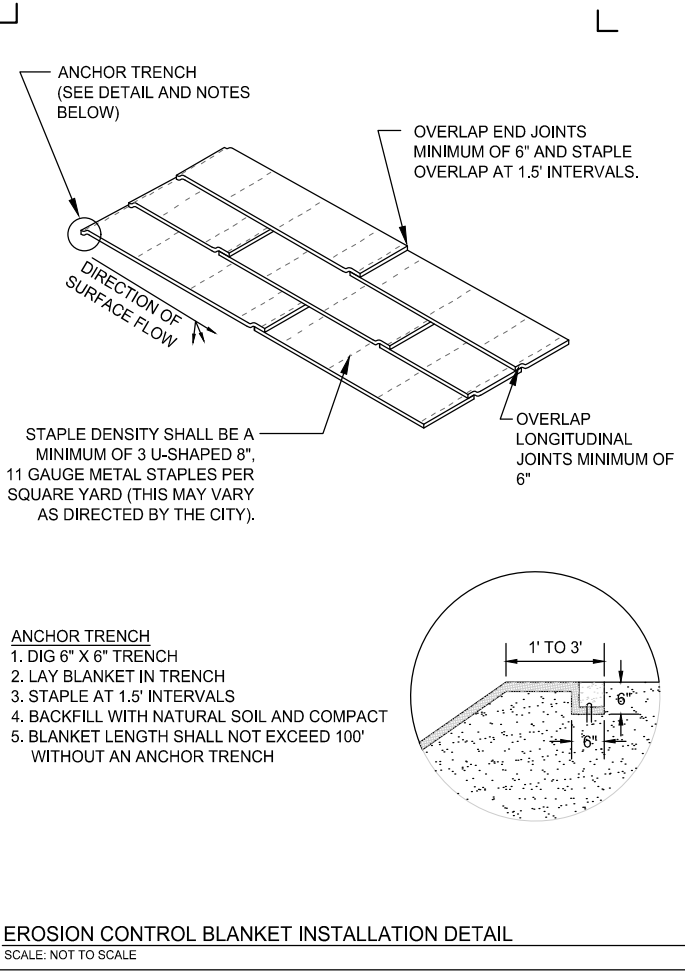
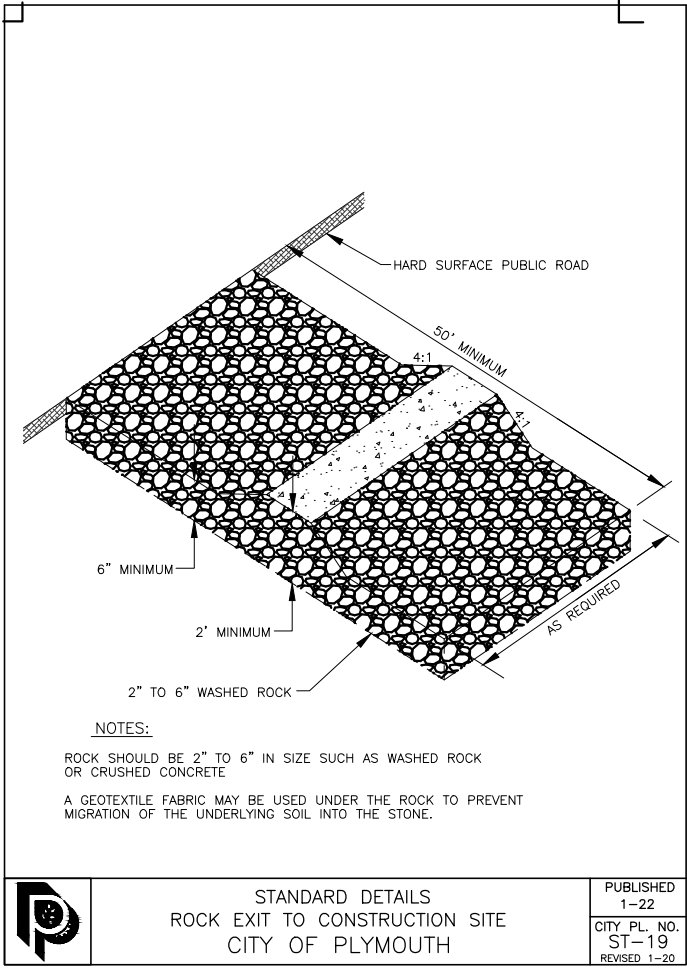
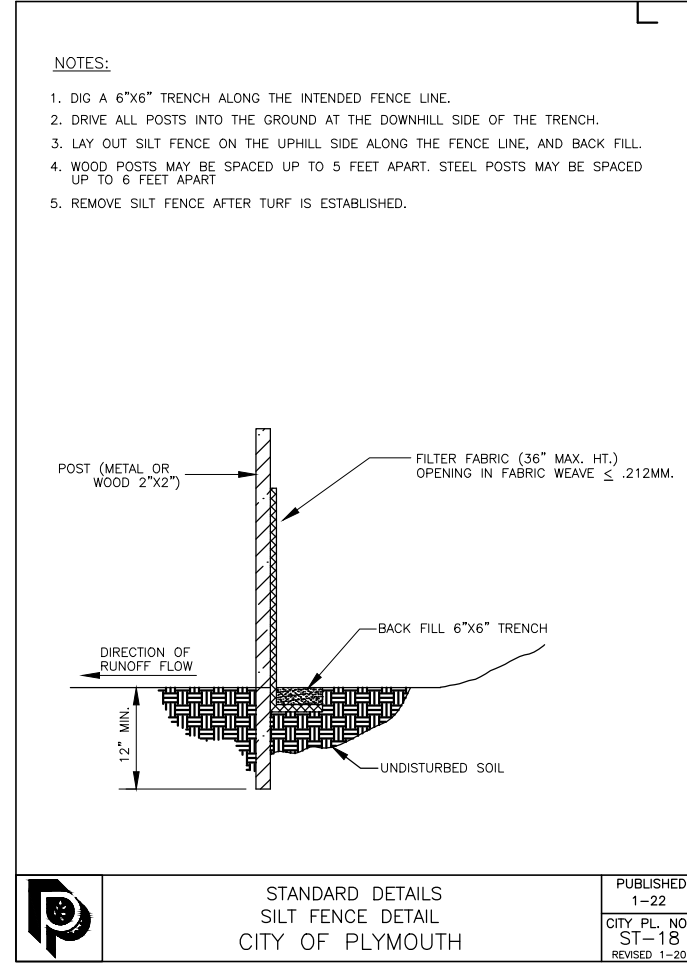
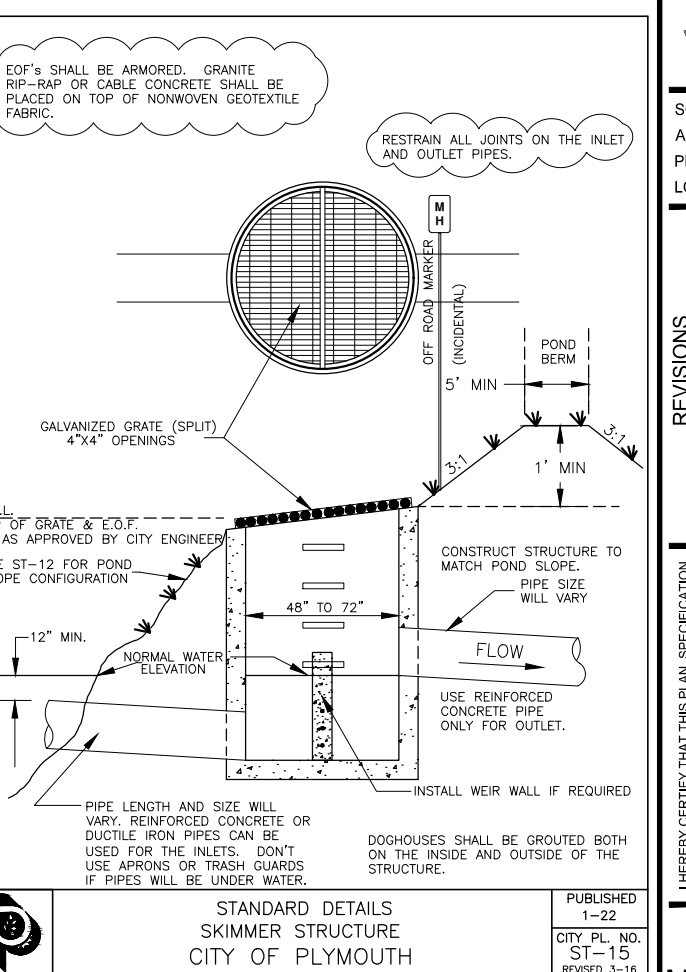
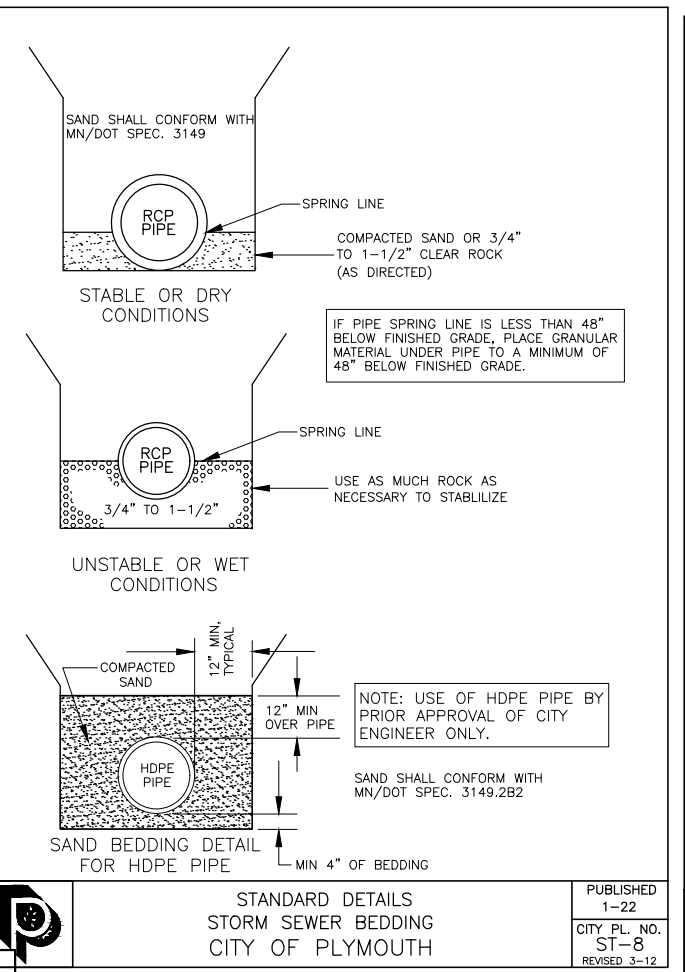
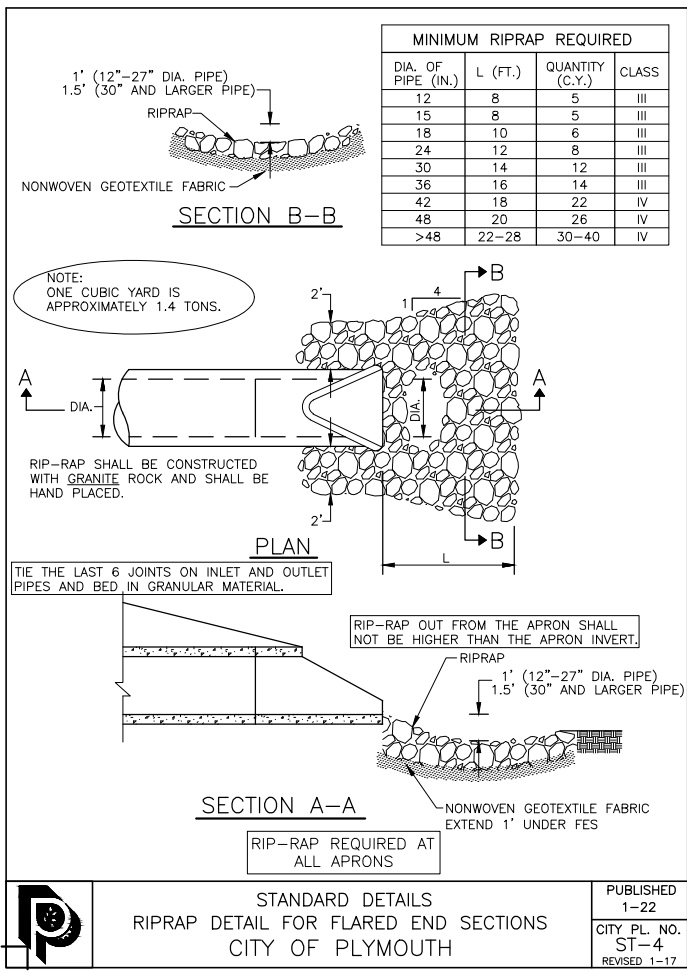
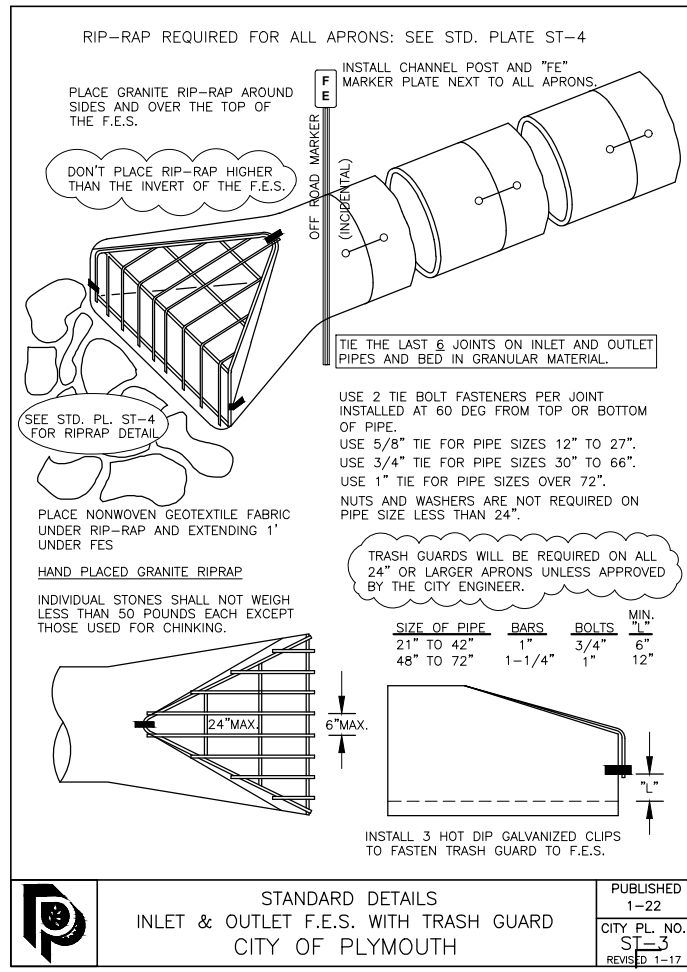

wsb City of Plymouth

SCALE: AS SHOWN
DESIGN BY: SML
PLAN BY: JHN
CHECK BY: JHN

REVISIONS	
NO.	DESCRIPTION

I HEREBY CERTIFY THAT THIS PLAN, SPECIFICATION, OR REPORT WAS PREPARED BY ME OR UNDER MY DIRECT SUPERVISION AND THAT I AM A DULY LICENSED PROFESSIONAL ENGINEER UNDER THE LAWS OF THE STATE OF MINNESOTA.

JACOB NEWHALL
LIC. NO. 49170
DATE: 11-23-2022

MISCELLANEOUS DETAILS

FOUR SEASONS WATER QUALITY PROJECT
CITY OF PLYMOUTH, MN

CLIENT PROJECT NO. WR220004
WSB PROJECT NO. 021322-000
SHEET 13 OF 13

K:\021322-000\Cad\Plan\021322-000-C-EROS-PLAN.dwg 12/5/2022 3:06:40 PM

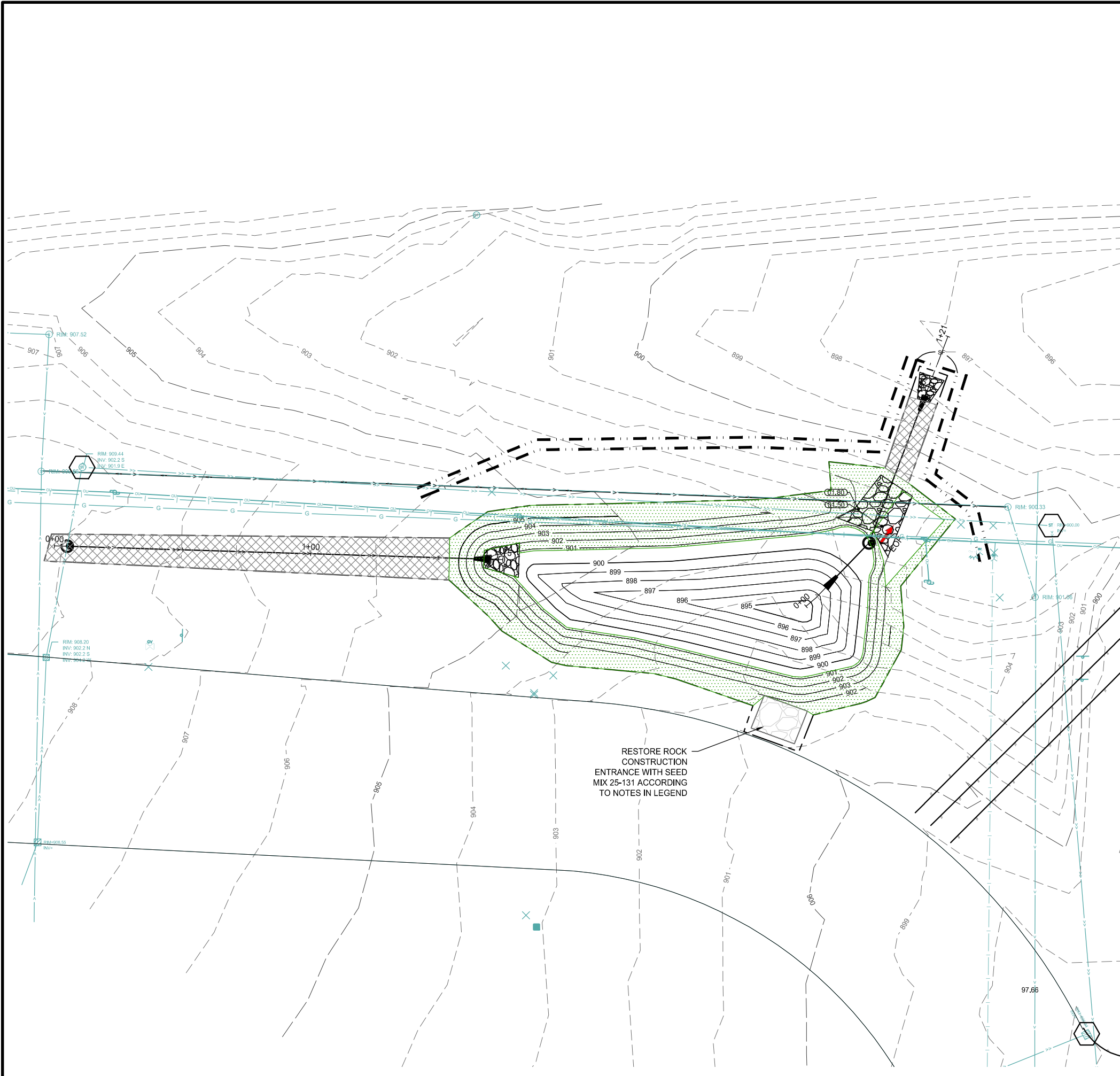

LOCATION

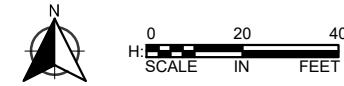

LEGEND

- INLET PROTECTION
- CLASS III RIP RAP
- SILT FENCE
- APPROX. CONSTRUCTION LIMITS
- WOOD FIBER BIROLL
- SEED MIX 25-131 (220 LBS/ACRE) WITH FERTILIZER TYPE 3 (350 LBS/ACRE) & TYPE 3 MULCH (2 TONS/ACRE) WITH DISC ANCHOR.
- SEED MIX 33-261 (35 LBS/ACRE) WITH FERTILIZER TYPE 4 (150LBS/ACRE) & CATEGORY 3N EROSION CONTROL BLANKET. TEMPORARY STABILIZATION: TYPE 3 MULCH WITH DISC ANCHOR
- TYPE 2 WETLAND: 6 INCHES OF WATER SEED MIX 34-271
- TYPE 3 WETLAND: 1-2 FEET OF WATER SEED MIX 34-181
- TYPE 4 WETLAND: ABOVE NWL SEED MIX 34-262
- 1019 - EXISTING CONTOUR (MAJOR)
- 1019 - EXISTING CONTOUR (MINOR)
- 1019 - PROPOSED CONTOUR (MAJOR)
- 1019 - PROPOSED CONTOUR (MINOR)
- EXISTING STORM SEWER PIPE
- EXISTING STORM STRUCTURE

EROSION CONTROL NOTES

1. RESTORE ALL POND EDGES AND WOODED AREAS WHERE DISTURBED OR AS DIRECTED BY ENGINEER IN FIELD WITH TYPE 33-261 SEED (35 LBS/AC) AND OATS (25-111) OR WINTER WHEAT (25-112) COVER CROP @ 100 LBS/AC. TYPE 33-261 SEED (35 LBS/AC) AND COVER CROP AND CATEGORY 3N EROSION CONTROL BLANKET SHALL BE INSTALLED ALONG POND EDGES, BUFFERS, AND NON-MOWABLE SLOPES AS DIRECTED BY THE ENGINEER IN THE FIELD.
2. RESTORE DISTURBED MOWED AREAS WITH TYPE 25-131 (220 LBS/AC) AS SHOWN IN PLANS.
3. ALL SOILS DISTURBED DURING CONSTRUCTION ACTIVITIES WILL BE STABILIZED FOLLOWING SEED MIXES, FERTILIZER, AND STABILIZING COVER OUTLINED WITHIN THESE PLANS. AREAS THAT ARE NOT ABLE TO BE FINE GRADED DUE TO FROST OR OTHER CONDITIONS WILL NEED TO BE FINE GRADED AND SEEDED AFTER APRIL 15TH.
4. IN THE EVENT THAT RESTORATION CANNOT BE IMPLEMENTED WITHIN 7 DAYS AFTER CONSTRUCTION ACTIVITY IN THE DISTURBED AREA HAS CEASED, TEMPORARY EROSION STABILIZATION BMPs (I.E. HYDRO MULCH 3884.B.2) MUST BE SCHEDULED TO OCCUR WITHIN THAT 7 DAY TIME FRAME.
5. CONTRACTOR RESPONSIBLE FOR THE DAMAGE TO STREETS, PARKING LOTS, CONCRETE CURB AND GUTTER, TRAIL, AND TREES NOT SHOWN TO BE REMOVED.
6. AT A MINIMUM, DAILY STREET SWEEPING REQUIRED DURING HAULING OPERATIONS, MORE AS NEEDED OR AS DIRECTED BY THE ENGINEER.
7. ALL STOCKPILES MUST HAVE DOWN GRADIENT PERIMETER SEDIMENT CONTROL IMPLEMENTED AND MAINTAINED AT ALL TIMES. STOCKPILES TO RECEIVE TEMPORARY STABILIZATION IF UNWORKED FOR 7 DAYS
8. CONTRACTOR SHALL PERFORM ALL DEWATERING AND EXCAVATION ONSITE AND OFF OF ROADWAY, AND LOAD AND HAUL OUT USING ACCESS ROUTE.
9. CONTRACTOR TO GRADE AROUND EXISTING STORM SEWER STRUCTURES AS DIRECTED BY THE ENGINEER.
10. CONTRACTOR TO COORDINATE ACCESS LIMITS WITH THE ENGINEER IN THE FIELD.
11. EXISTING POND CONTOURS DEVELOPED FROM PRE-DESIGN SURVEY.

REVISIONS	
NO.	DESCRIPTION

I HEREBY CERTIFY THAT THIS PLAN, SPECIFICATION, OR REPORT WAS PREPARED BY ME OR UNDER MY DIRECT SUPERVISION AND THAT I AM A DULY LICENSED PROFESSIONAL ENGINEER UNDER THE LAWS OF THE STATE OF MINNESOTA.

JACOB NEWMHALL
 DATE: 12-05-2022 LIC. NO.: 49170

EROSION CONTROL PLAN
 BASIN WP

FOUR SEASONS WATER QUALITY PROJECT
 CITY OF PLYMOUTH, MN

CLIENT PROJECT NO.
 WR220004

WSB PROJECT NO.
 021322-000

SHEET
 11 OF 13

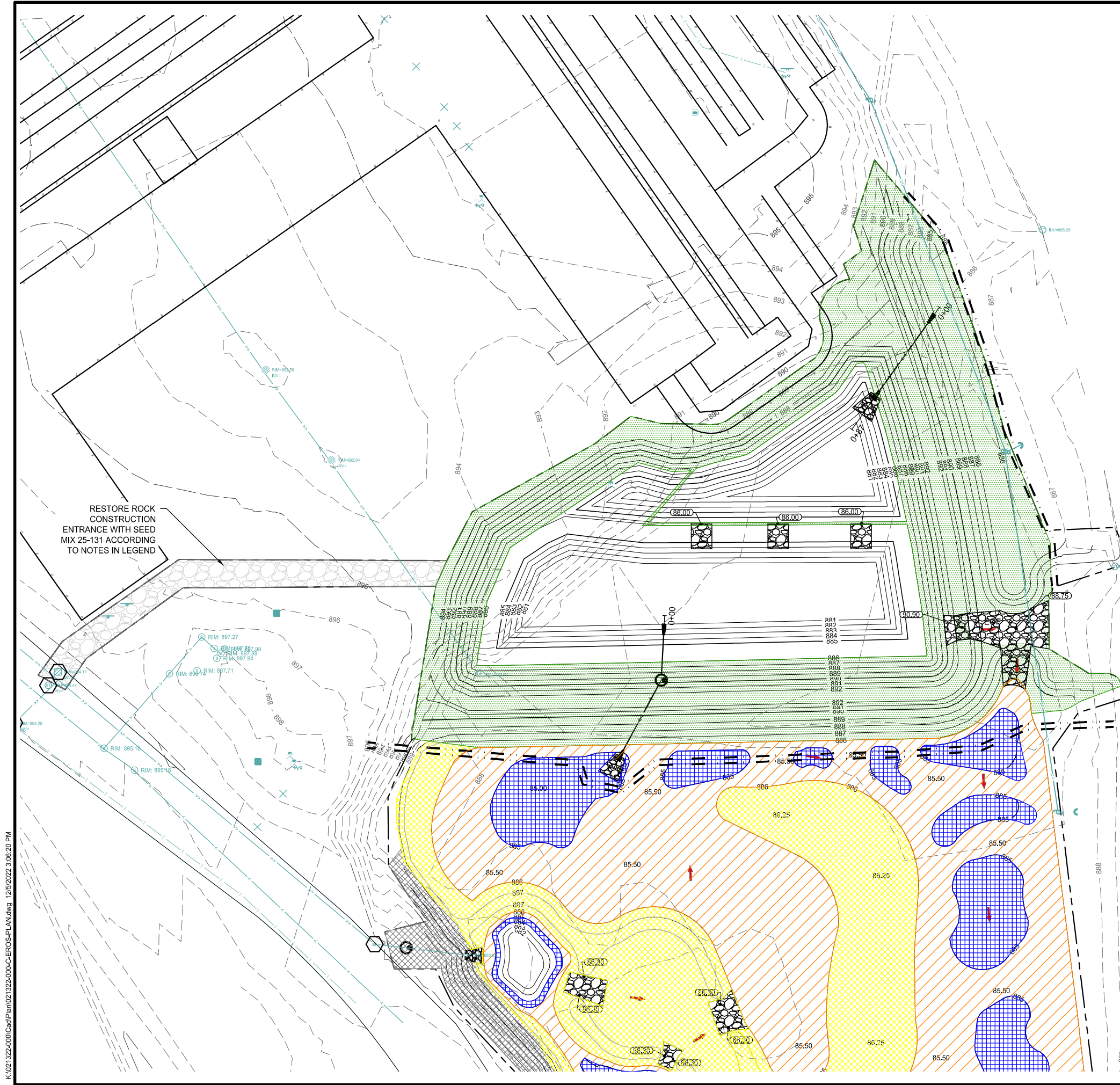

LOCATION



LEGEND

- INLET PROTECTION
- CLASS III RIP RAP
- SILT FENCE
- APPROX. CONSTRUCTION LIMITS
- WOOD FIBER BIOROLL
- SEED MIX 25-131 (220 LBS/ACRE) WITH FERTILIZER TYPE 3 (350 LBS/ACRE) & TYPE 3 MULCH (2 TONS/ACRE) WITH DISC ANCHOR.
- SEED MIX 33-261 (35 LBS/ACRE) WITH FERTILIZER TYPE 4 (150 LBS/ACRE) & CATEGORY 3N EROSION CONTROL BLANKET. TEMPORARY STABILIZATION: TYPE 3 MULCH WITH DISC ANCHOR
- TYPE 2 WETLAND: 6 INCHES OF WATER SEED MIX 34-271
- TYPE 3 WETLAND: 1-2 FEET OF WATER SEED MIX 34-181
- TYPE 4 WETLAND: ABOVE NWL SEED MIX 34-262
- 1019 EXISTING CONTOUR (MAJOR)
- 1019 EXISTING CONTOUR (MINOR)
- 1019 PROPOSED CONTOUR (MAJOR)
- 1019 PROPOSED CONTOUR (MINOR)
- EXISTING STORM SEWER PIPE
- EXISTING STORM STRUCTURE

EROSION CONTROL NOTES

1. RESTORE ALL POND EDGES AND WOODED AREAS WHERE DISTURBED OR AS DIRECTED BY ENGINEER IN FIELD WITH TYPE 33-261 SEED (35 LBS/AC) AND OATS (25-111) OR WINTER WHEAT (25-112) COVER CROP @ 100 LBS/AC. TYPE 33-261 SEED (35 LBS/AC) AND COVER CROP AND CATEGORY 3N EROSION CONTROL BLANKET SHALL BE INSTALLED ALONG POND EDGES, BUFFERS, AND NON-MOWABLE SLOPES AS DIRECTED BY THE ENGINEER IN THE FIELD.
2. RESTORE DISTURBED MOWED AREAS WITH TYPE 25-131 (220 LBS/AC) AS SHOWN IN PLANS.
3. ALL SOILS DISTURBED DURING CONSTRUCTION ACTIVITIES WILL BE STABILIZED FOLLOWING SEED MIXES, FERTILIZER, AND STABILIZING COVER OUTLINED WITHIN THESE PLANS. AREAS THAT ARE NOT ABLE TO BE FINE GRADED DUE TO FROST OR OTHER CONDITIONS WILL NEED TO BE FINE GRADED AND SEEDING AFTER APRIL 15TH.
4. IN THE EVENT THAT RESTORATION CANNOT BE IMPLEMENTED WITHIN 7 DAYS AFTER CONSTRUCTION ACTIVITY IN THE DISTURBED AREA HAS CEASED, TEMPORARY EROSION STABILIZATION BMPs (I.E. HYDRO MULCH 3884.B.2) MUST BE SCHEDULED TO OCCUR WITHIN THAT 7 DAY TIME FRAME.
5. CONTRACTOR RESPONSIBLE FOR THE DAMAGE TO STREETS, PARKING LOTS, CONCRETE CURB AND GUTTER, TRAIL, AND TREES NOT SHOWN TO BE REMOVED.
6. AT A MINIMUM, DAILY STREET SWEEPING REQUIRED DURING HAULING OPERATIONS, MORE AS NEEDED OR AS DIRECTED BY THE ENGINEER.
7. ALL STOCKPILES MUST HAVE DOWN GRADIENT PERIMETER SEDIMENT CONTROL IMPLEMENTED AND MAINTAINED AT ALL TIMES. STOCKPILES TO RECEIVE TEMPORARY STABILIZATION IF UNWORKED FOR 7 DAYS
8. CONTRACTOR SHALL PERFORM ALL DEWATERING AND EXCAVATION ONSITE AND OFF OF ROADWAY, AND LOAD AND HAUL OUT USING ACCESS ROUTE.
9. CONTRACTOR TO GRADE AROUND EXISTING STORM SEWER STRUCTURES AS DIRECTED BY THE ENGINEER.
10. CONTRACTOR TO COORDINATE ACCESS LIMITS WITH THE ENGINEER IN THE FIELD.
11. EXISTING POND CONTOURS DEVELOPED FROM PRE-DESIGN SURVEY.

RESTORE ROCK CONSTRUCTION ENTRANCE WITH SEED MIX 25-131 ACCORDING TO NOTES IN LEGEND

SCALE: AS SHOWN
 PLAN BY: LGR
 DESIGN BY: SML
 CHECK BY: JHN

REVISIONS	
NO.	DESCRIPTION

I HEREBY CERTIFY THAT THIS PLAN, SPECIFICATION, OR REPORT WAS PREPARED BY ME OR UNDER MY DIRECT SUPERVISION AND THAT I AM A DULY LICENSED PROFESSIONAL ENGINEER UNDER THE LAWS OF THE STATE OF MINNESOTA.

JACOB NEUHAL
 DATE: 12-05-2022 LIC. NO.: 49170

EROSION CONTROL PLAN BASIN NP

**FOUR SEASONS WATER QUALITY PROJECT
 CITY OF PLYMOUTH, MN**

CLIENT PROJECT NO. WR220004

WSB PROJECT NO. 021322-000

SHEET 12 OF 13



LOCATION

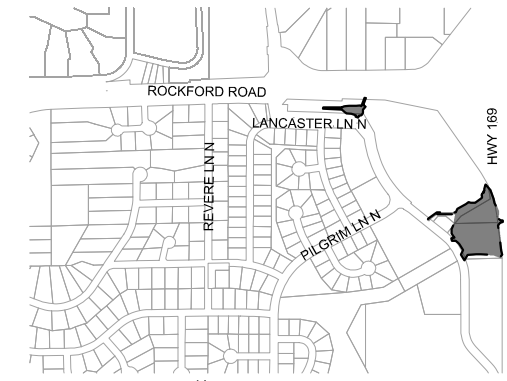

LEGEND

- INLET PROTECTION
- CLASS III RIP RAP
- SILT FENCE
- APPROX. CONSTRUCTION LIMITS
- WOOD FIBER BIOROLL
- SEED MIX 25-131 (220 LBS/ACRE) WITH FERTILIZER TYPE 3 (350 LBS/ACRE) & TYPE 3 MULCH (2 TONS/ACRE) WITH DISC ANCHOR.
- SEED MIX 33-261 (35 LBS/ACRE) WITH FERTILIZER TYPE 4 (150LBS/ACRE) & CATEGORY 3N EROSION CONTROL BLANKET. TEMPORARY STABILIZATION: TYPE 3 MULCH WITH DISC ANCHOR
- TYPE 2 WETLAND: 6 INCHES OF WATER SEED MIX 34-271
- TYPE 3 WETLAND: 1-2 FEET OF WATER SEED MIX 34-181
- TYPE 4 WETLAND: ABOVE NWL SEED MIX 34-262
- 1019 EXISTING CONTOUR (MAJOR)
- 1019 EXISTING CONTOUR (MINOR)
- 1019 PROPOSED CONTOUR (MAJOR)
- 1019 PROPOSED CONTOUR (MINOR)
- EXISTING STORM SEWER PIPE
- EXISTING STORM STRUCTURE

EROSION CONTROL NOTES

1. RESTORE ALL POND EDGES AND WOODED AREAS WHERE DISTURBED OR AS DIRECTED BY ENGINEER IN FIELD WITH TYPE 33-261 SEED (35 LBS/AC) AND OATS (25-111) OR WINTER WHEAT (25-112) COVER CROP @ 100 LBS/AC. TYPE 33-261 SEED (35 LBS/AC) AND COVER CROP AND CATEGORY 3N EROSION CONTROL BLANKET SHALL BE INSTALLED ALONG POND EDGES, BUFFERS, AND NON-MOWABLE SLOPES AS DIRECTED BY THE ENGINEER IN THE FIELD.
2. RESTORE DISTURBED MOWED AREAS WITH TYPE 25-131 (220 LBS/AC) AS SHOWN IN PLANS.
3. ALL SOILS DISTURBED DURING CONSTRUCTION ACTIVITIES WILL BE STABILIZED FOLLOWING SEED MIXES, FERTILIZER, AND STABILIZING COVER OUTLINED WITHIN THESE PLANS. AREAS THAT ARE NOT ABLE TO BE FINE GRADED DUE TO FROST OR OTHER CONDITIONS WILL NEED TO BE FINE GRADED AND SEEDDED AFTER APRIL 15TH.
4. IN THE EVENT THAT RESTORATION CANNOT BE IMPLEMENTED WITHIN 7 DAYS AFTER CONSTRUCTION ACTIVITY IN THE DISTURBED AREA HAS CEASED, TEMPORARY EROSION STABILIZATION BMPs (I.E. HYDRO MULCH 3884.B.2) MUST BE SCHEDULED TO OCCUR WITHIN THAT 7 DAY TIME FRAME.
5. CONTRACTOR RESPONSIBLE FOR THE DAMAGE TO STREETS, PARKING LOTS, CONCRETE CURB AND GUTTER, TRAIL, AND TREES NOT SHOWN TO BE REMOVED.
6. AT A MINIMUM, DAILY STREET SWEEPING REQUIRED DURING HAULING OPERATIONS, MORE AS NEEDED OR AS DIRECTED BY THE ENGINEER.
7. ALL STOCKPILES MUST HAVE DOWN GRADIENT PERIMETER SEDIMENT CONTROL IMPLEMENTED AND MAINTAINED AT ALL TIMES. STOCKPILES TO RECEIVE TEMPORARY STABILIZATION IF UNWORKED FOR 7 DAYS
8. CONTRACTOR SHALL PERFORM ALL DEWATERING AND EXCAVATION ONSITE AND OFF OF ROADWAY, AND LOAD AND HAUL OUT USING ACCESS ROUTE.
9. CONTRACTOR TO GRADE AROUND EXISTING STORM SEWER STRUCTURES AS DIRECTED BY THE ENGINEER.
10. CONTRACTOR TO COORDINATE ACCESS LIMITS WITH THE ENGINEER IN THE FIELD.
11. EXISTING POND CONTOURS DEVELOPED FROM PRE-DESIGN SURVEY.

SCALE: AS SHOWN
 PLAN BY: LGR
 DESIGN BY: SML
 CHECK BY: JHN

REVISIONS	
NO.	DESCRIPTION

I HEREBY CERTIFY THAT THIS PLAN, SPECIFICATION, OR REPORT WAS PREPARED BY ME OR UNDER MY DIRECT SUPERVISION AND THAT I AM A DULY LICENSED PROFESSIONAL ENGINEER UNDER THE LAWS OF THE STATE OF MINNESOTA.

JACOB NEWMALL
 DATE: 12-05-2022 LIC. NO.: 49170

EROSION CONTROL PLAN WETLAND

FOUR SEASONS WATER QUALITY PROJECT
 CITY OF PLYMOUTH, MN

CLIENT PROJECT NO. WR220004

WSB PROJECT NO. 021322-000

SHEET 13 OF 13

K:\021322-000\Cadd\Plan\021322-000-C-EROS-PLAN.dwg 12/5/2022 3:04:45 PM